

Installation Guide



Solar Climate Control System (Standard)

For Buildings with a Roof Cavity



SUN LIZARD Pty Ltd
PO Box 276 Mt Evelyn, VIC 3796
P: (03) 9722 9596
F: (03) 9723 0253
M: 0418 576 600
www.sunlizard.com.au

Current as of 31 Oct 2007

TABLE OF CONTENTS

1. INTRODUCTION	5
2. HANDLING & UNPACKING	5
3. INVENTORY CHECKLIST	5
4. IMPORTANT NOTES BEFORE INSTALLING A SUN LIZARD	7
5. SELECTING LOCATION FOR THE SOLAR HEAT COLLECTOR	7
6. SELECTING A LOCATION FOR THE PV PANEL	10
7. SELECTING A LOCATION FOR THE FAN BOX	10
8. SELECTING A LOCATION FOR THE AIR FLOW CONTROL BOX.....	10
9. SELECTING A LOCATION FOR THE ELECTRONIC CONTROL SYSTEM	11
10. SELECTING A LOCATION FOR THE CEILING DIFFUSER (INLET RETURN)	11
11. SELECTING A LOCATION FOR THE EXHAUST FLUE	11
12. INSTALLING THE INLET & OUTLET ADAPTOR TO THE SOLAR HEAT COLLECTOR	12
13. ASSEMBLING THE NS FRAME ON TO SOLAR COLLECTOR (IF REQUIRED).....	14
14. INSTALLING SOLAR HEAT COLLECTOR WITH A NS FRAME ON TO THE ROOF	14
15. ASSEMBLING THE EW FRAME FOR THE SOLAR HEAT COLLECTOR	17
16. INSTALLING THE SOLAR HEAT COLLECTORS WITH AN EW FRAME.....	20
17. PENETRATING THE ROOF	23
18. FITTING CEILING DIFFUSER.....	25
19. CONNECTING DUCTING	25
20. CONNECTING THE ELECTRONIC CONTROL SYSTEM (ECS), TO CABLE AND SWITCH	27
21. CONNECTING THE ELECTRONIC CONTROL SYSTEM (ECS), TO FAN BOX.....	28
22. CONNECTING THE ELECTRONIC CONTROL SYSTEM (ECS) TO AIR FLOW CONTROL BOX	28
23. CONNECTING THE ELECTRONIC CONTROL SYSTEM (ECS), TO PV PANEL.....	28
24. FITTING PV PANEL ON ROOF.....	30
25. CONNECTING EXHAUST COWL	33
26. CONNECTING THE ELECTRONIC CONTROL SYSTEM (ECS), TO MAINS POWER	33
27. TESTING THE SYSTEM	34
28. FINISHING THE JOB	34
29. SWITCH OPERATION	34

DISCLAIMER

Sun Lizard Pty Ltd is not responsible for any injury or damage resulting from the product being installed persons installing it themselves or by non-accredited Sun Lizard installer.

We highly recommend professional installation by our Accredited Sun Lizard Installers. Improper installation is considered personal damage and cannot be refunded or returned for replacement. Physical damage includes but is not limited to improper handling or the type of damage sustained by irregular usage. Proof of professional installation must be shown to warrant any item purchased from distinct.

Care and caution should be exercised by those installing their own systems. Any person installing a Sun Lizard system with the use of our installation guides must accept full responsibility for any injury or mishap resulting from following the guide. Following the provided installation guides will be at you own risk and, if in doubt, consult a professional Sun Lizard Installer.

Notice

The information in this manual is subject to change without notification. Additional pages may be inserted in future editions. The user is asked to excuse any technical inaccuracies or typographical errors in the present edition.

This manual, any copyrightable subject matter sold or provided with or in connection with the sale of the Sun Lizard products are protected by copyright. All rights are reserved. Copying or other reproduction of all or part of this manual, any copyrightable subject matter without the prior written consent of Sun Lizard Pty Ltd is prohibited. Any copies made of all or part of this manual, any copyrightable subject must contain the same copyright notice as the material

from which the copying is done.

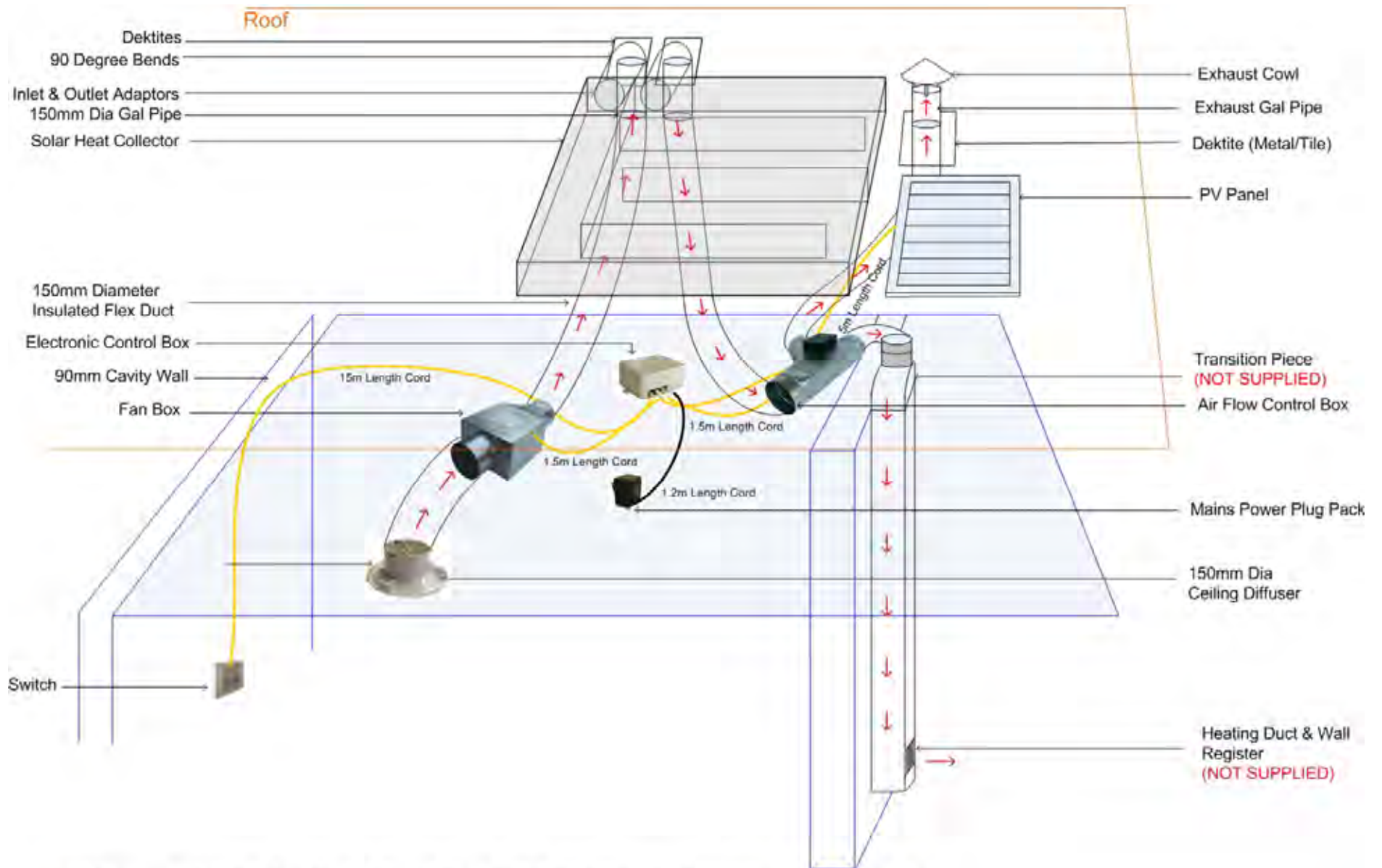

INSTALLATION OF SINGLE SOLAR CLIMATE CONTROL SYSTEM (STANDARD)

FOR BUILDINGS WITH ROOF CAVITIES

1. Introduction

Congratulations on your purchase of a Sun Lizard Climate Control System and reducing your contribution to Australia's greenhouse gas emission.

The Sun Lizard has been designed to install quickly and easily to most buildings. Prior to commencing the installation of the Sun Lizard, please read the following installation guide carefully and if in doubt, contact your local distributor or installer.

For an overview of the installation please see the previous page.

2. Handling & Unpacking

Carefully remove the items from the boxes. Please take note of these general precautions.

PV Panel

- When handling the Photovoltaic Panel, take extreme care, as the glass is fragile.
- Do not twist or bend the Photovoltaic Panel; always lay the panel on a flat surface.
- When moving the Photovoltaic Panel, ensure that it is lifted by its side and not by the corners.
- Do not place tools or other heavy objects on the glass even with the protective cover in place. Glass breakage during installation or through negligence will not be covered under warranty.

Solar Heat Collector

- Each collector weighs approximately 60kg. It is important that at least two strong persons are available to lift and handle the systems on site.
- When handling the collector, take extreme care, as the glass is fragile.
- Avoid placing the panels on any uneven surfaces
- Do not twist or bend the collector; always lay the collector on a flat surface.
- When moving the collector, ensure that it is lifted by its side and not by the corners.
- Do not place tools or other heavy objects on the glass even with the protective cover in place. Glass breakage during installation or through negligence will not be covered under warranty.

Throughout the installation of the Sun Lizard, the installer should ensure that the Product Specifications are not compromised.

3. Inventory Checklist

Check the following items are included in the package:
Single Climate Control System (Standard)

- 1 x Solar Heat Collector (Left Hand or Right Hand Inlet/Outlet)
- 1 x PV Panel
- 1 x Air Flow Control Box
- 1 x Fan Box
- 1 x Electronic Control System
- 1 x Switch
- 1 x Switch Cable
- 1 x Exhaust Pipe
- 1 x Exhaust Cowl

What You Will Need

- Duct Tape
- Silicon Sealer
- Screw Driver
- Adjustable Spanner
- Scissors
- Tek screws
- 15mm Drill Bit and Drill
- Plasterboard Screws
- Conduit (for solid walls only)
- Razor Blade / Stanley Knife
- Roofing Screws

- 1 x Dektite (For Metal / Tiled Roof)
- 1 x Ceiling Diffuser
- 2 x Insulated Flexible Ducting
- 2 x Gal Pipe
- 3 x Dektites (Metal/Tile)
- 2 x Metal Bends
- 1 x PV Frame
- 4 x Square Predrilled Tube

Optional components supplied with Sun Lizard if ordered include

- Filtered cooling vents (Floor Register, Boot & Filter)
- 240/12 volt plug pack

If items are missing please contact us on (03) 9722 9596.

- Hack Saw
- Hoop Iron or Metal Strapping (for tiled roof only)

Where possible, please recycle all packaging. If you have received a number of Sun Lizards, your local distributor may collect packaging for reuse. Unfortunately, the cost to ship empty packaging back exceeds the cost of new packaging unless it is done in bulk. We have tried to use recycled materials, offcuts and recyclable components to reduce waste.

4. **Important Notes before Installing a Sun Lizard**

It is recommended that a qualified tradesman be used to install the Sun Lizard Climate Control System and to:

- Complete the installation and ensure that the Sun Lizard is correctly mounted to withstand any extreme local conditions.
- Complete all roof penetrations to meet any local regulations.

While it is possible for a home handyman to do the installation, local regulatory requirements may necessitate the use of a qualified tradesman. While no warranty will be void if a qualified tradesman is not used, no responsibility for roof leaks or other possible damage through incorrect installation will be entertained.

To avoid damaging any of the components, it is recommended to assemble the Sun Lizard on the roof as part of the installation procedure. If assembly is impossible on the roof of the building, then assembly should occur prior to installation.

We recommend laying out all the components in a dummy assembly to ensure you are familiar with how they will all fit together. Do this on the ground first and then on and in the roof. This is also useful to ensure you keep ducting to a minimum and have all the components required prior to commencing installation.

NOTE: the Colorbond finish of the Sun Lizard may have a plastic film to prevent scratches during manufacture. In some cases there may still be a film attached to the outer panels. Once the Sun Lizard is securely in place, this film can be removed.

5. **Selecting Location for the Solar Heat Collector**

The Sun Lizard should be installed on the roof of your building as close as possible to the following conditions:

1. The most effective direction to install the Sun Lizard is between 5 degrees East and 10 West of due North. Installation outside of this orientation will degrade performance to some degree. Local conditions may require minor changes to this ideal.
2. If no roof surface faces North, then an Elevation Frame (which come as a North/South Frame or East/West Frame) may need to be used to achieve the optimum performance. If you have not purchased additional frames for your specific roof type, please contact your local distributor or contact us direct to aid you in the selection of the appropriate accessories.
3. The Sun Lizard requires the sun to work. If trees shade your roof during the day, the Sun Lizard will not be as effective, or in extreme cases, it may not work at all. Ensure that minimal shading occurs on the roof (where the proposed location of the Sun Lizard is to be) during the day. The elevation of the sun and therefore any shading will vary throughout the year and is different in various parts of Australia. If you are unsure, please talk to your local distributor or contact us



Map showing Latitude for Australian cities

Latitudinal Range	Solar Heat Collector		Examples of Major Centers
	Optimum Elevation	Elevation Range	
15°-20°	5°S-0°	15°S-10°N	Cairns

direct.

4. The Solar Heat Collectors will need to be mounted at an angle that is suited for your location to ensure the Solar Heat Collectors obtain the maximum solar gain. Please refer to the map and tables to the right to determine the optimum tilt angle (elevation from horizontal). If unsure, please talk to your local distributor or contact us direct.
5. There are limitations on the length of inlet and outlet ducting that can be installed with the Sun Lizard. The selected position for the Sun Lizard and all components must be such that it does not exceed the **maximum 12m length** inclusive of both inlet and outlet duct lengths. The shorter the duct length, the more efficient the Sun Lizard will work.

For How to Install the Solar Heat Collector on to the roof please see

6. Use extreme care to lift the 60Kg Solar Collectors onto the roof. Use an elevator or lift if available or at least 4 men and enough ropes and ladders to ensure safety at all times.
7. Mount the Solar Collector to the roof of your building (or if using an elevation frame, to the frame itself - see below).
8. With a tile roof, use the mounting brackets (if supplied) or metal strapping tape to slide under the roof tile, and fit to a roof batten.
9. With a metal roof, mount the Solar Heat Collector directly to the roof, ensuring that the mounting bolts are also bolted to the roof battens or strapping tape is secured to the roof and collector.

Once the Solar Collector is mounted, ensure that it is secure enough to withstand any extreme local weather conditions. It is the responsibility of the installer to ensure that the Sun Lizard is correctly installed and secured to the roof of the building so

20°-25°	0°- 5°N	10°S-15°N	Mackay Rockhampton
25°-30°	5°N - 10°N	5°S-20°N	Brisbane, Gold Coast, Geraldton
30°-35°	10°N-15°N	0°-25°N	Port Macquarie, Newcastle, Gosford, Sydney, Adelaide, Perth
35°-40°	15°N-20°N	5°N-30°N	ACT, Melbourne, Ballarat, Bendigo, Geelong
40°-45 °	20°N-25°N	10°N-35°N	Devonport, Launceston, Hobart



that it will withstand all weather conditions.



6. Selecting a Location for the PV Panel

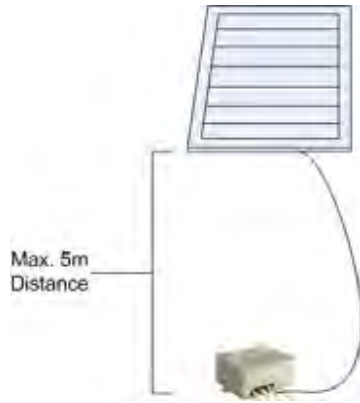

The Sun Lizard PV Panel should be installed on the roof of your building as close as possible to the following conditions:

- a) The most effective direction to install the PV Panel is between 5 degrees East to 10 West of due North. Installation outside of this orientation will degrade performance to some degree. Local conditions may require minor changes to this ideal.
- b) If no roof surface faces North, then the PV Mounting Frame may need to be used to achieve the optimum performance. A west facing roof is preferred over a east facing roof as the sun's intensity is greater in the afternoons.
- c) The Sun Lizard requires the sun to work. If trees shade your roof during the day, the Sun Lizard will not be as effective, or in extreme cases, it may not work at all. Ensure that minimal shading occurs on the roof (where the proposed location of the Sun Lizard is to be) during the day.
- d) The PV Panel will need to be mounted at an angle that is suited for your location to ensure the PV Panel obtains the maximum solar gain. Please refer to the map and table on the right to determine the optimum tilt angle (elevation from horizontal).
- e) PV Panel should be located within a 5m distance from the electronic control system as cable included in the package is 5m in length.

If you are unsure, please talk to your local distributor or contact us direct.



Latitudinal Range	PV Panel		Examples of Major Centres
	Optimum Elevation	Elevation Range	
15°-20°	5°N - 10°N	0°N-20°N	Cairns
20°-25°	10°N - 15°N	5°N-25°N	Mackay Rockhampton
25°-30°	15°N-20°N	10°N-30°N	Brisbane, Gold Coast, Geraldton
30°-35°	20°N-25°N	15°N-35°N	Port Macquarie, Newcastle, Gosford, Sydney, Adelaide, Perth
35°-40°	25°N-30°N	20N-40°N	ACT, Melbourne, Ballarat, Bendigo, Geelong
40°-45 °	30°N-35 °N	25°N-45°N	Devonport, Launceston, Hobart

7. Selecting a Location for the Fan Box

- a) Locate the Fan Box inside the ceiling cavity in between the ceiling diffuser(s) and the exhaust gal pipe.
- b) The Fan Box should not be connected too close to the ceiling diffuser to avoid fan noise coming into the room via the ducting.
- c) It should be located at the furthest point from the ceiling diffuser, just before it goes through the roof.

8. Selecting a location for the

- a) Locate the Air Flow Control Box inside the ceiling cavity next to the Fan Box and before the exhaust flue.
- b) Make sure the inlets and outlets of the Air Flow Control Box are

Air Flow Control Box

9. Selecting a location for the Electronic Control System

facing the correct way (see step 13)

- a) Locate the Electronic Control System either inside the ceiling cavity or inside a cupboard away from dampness and excessive heat close to the fan box and airflow control box.
- b) Ensure that when connecting any cables that moisture and condensation will not run down the cables into the control box.
- c) There is a rechargeable battery inside the Electronic Control System that needs to be replaced every 4 years to ensure performance. Locate the box in an accessible location.

Please note that the cable from the Electronic Control System to the Fan Box and Air Flow Control Box is limited to 1.5m in length and to the Power Point is 1.2m

10. Selecting a location for the Ceiling Diffuser (Inlet Return)

Locate the ceiling diffuser where you wish to exhaust the hot air out of the building or shift the air to a different part of the house.

Recommendations for:

- a) A sloped ceiling: the diffuser should be located at its highest point.
- b) A flat ceiling: the diffuser should be located close to the northern side of the room.
- c) On a wall adjacent to a ceiling cavity, but above head height.

In two story buildings, the diffuser should be located in the upper story.

For buildings with no ceiling cavity, the register is usually fitted or taped to the 150mm pipe coming through the roof which connects to the solar heat collector inlet

11. Selecting a location for the Exhaust Flue

Locate the exhaust flue (comprising of a Gal Pipe, Cowl Hat and Dektite) on the roof and as close to Air Flow Control Box as possible. The exhaust flue should not exceed a distance of 6m from the Ceiling Diffuser.

12. Installing the Inlet & Outlet Adaptor to the Solar Heat Collector

- Remove 6 nuts at rear of solar heat collector and take off cover plates and flat plate strips.
- Fit inlet/outlet adaptor and replace nuts and flat plate strips (washers) as shown to the right. A bead of silicone should be run along the upper edge of the adaptor to stop water from coming into the collector.



13. Installing the Solar Heat Collector without a Frame

- To connect the NS frame to the collector, slide the 4 short pieces of 550mm square tube supplied with the collector into the top hat section underneath the collector in each corner.
- Slide to the second bolt hole and secure using the supplied bolts, washer and nuts. The 4 pieces of tube will now have one bolt hole showing on each corner. **NOTE** If you choose to mount the PV Panel to the collector (See the 3 available frame Arrangements for further details in Step 24) use one of the square tubes from the PV Frame Kit and fit to the Top Hat section.

For a tiled roof

- Position the Solar Heat Collector so it is facing North. You may need to use rope to temporarily hold the frame and collector in position.
- Using the tiled roof brackets (or alternatively hoop iron), lift the tiles and fix the brackets to the roof truss using roofing screws. Ensure that the structure is secure.
- Place the 4 short pieces of 550mm short square tube over the tiled roof brackets
- Drilling a 8mm hole into the square tube and bracket and secure the collector to the bracket by using the nuts and bolts supplied with the collector.

For a metal roof

- Position the Solar Heat Collector so it is facing North. You may need to use rope to temporarily hold the frame and collector in position.
- Drill one roofing screw into each short square tube to secure the collector into position

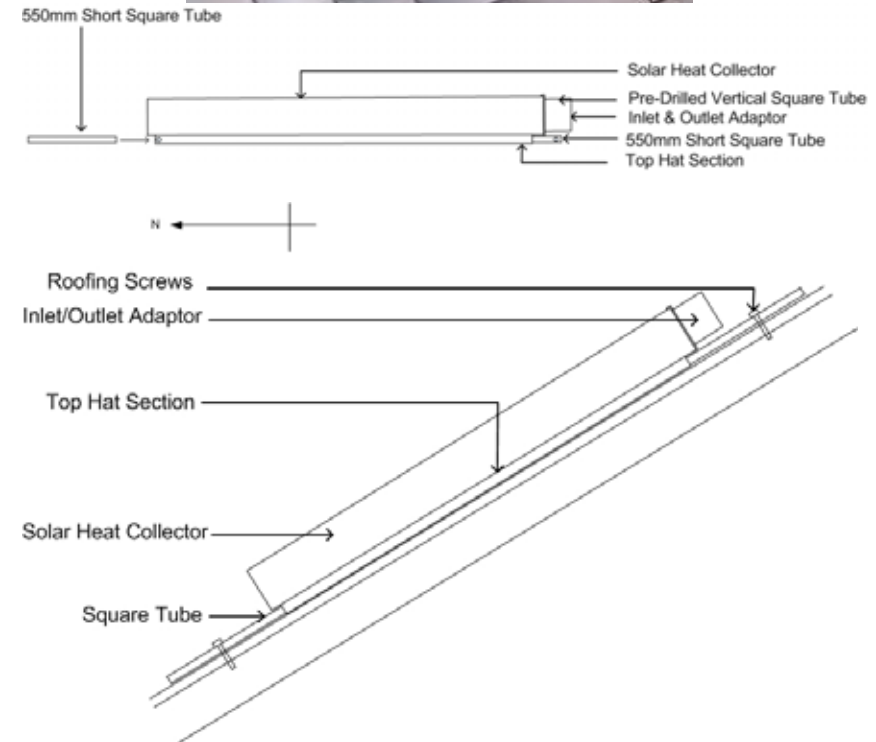

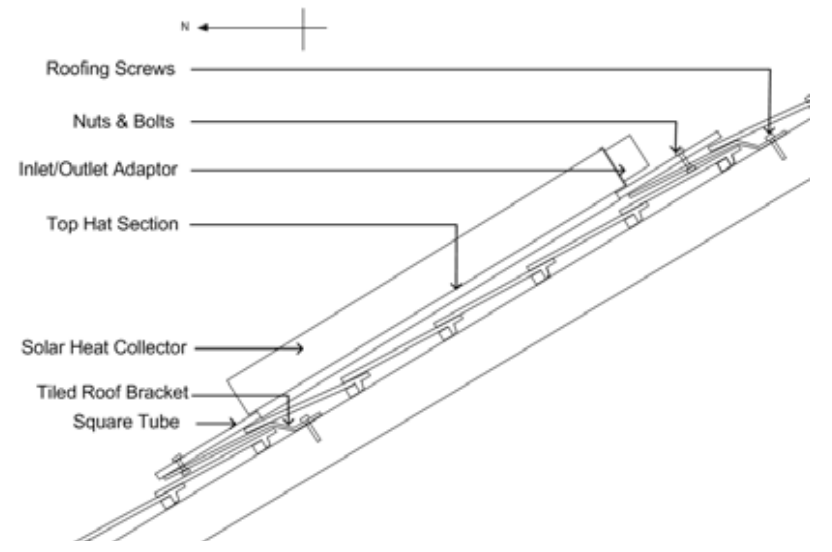

14. Assembling the NS Frame on to Solar Collector

- The Elevation Frame NS can be used to increase or decrease the angle of the solar heat collector. It consists of a long piece of square tube which is fitted to the roof and a shorter vertical upright with predrilled holes to adjust the height. Three hinges are used to connect the 2 pieces of square tube and the collector.
- Assemble two sets of the tube and hinges as shown in the right to create the NS Frame.
- To increase the angle the vertical/upright section is placed to the south, to decrease the angle (a very steep northern roof) the vertical/upright is placed to the north.
- The predrilled holes in the Elevation Frame NS vertical/upright section are at 5 degree intervals starting at 10 degrees. The tube inside the collector also has a number of predrilled holes that correspond to the angle. For each additional hole up on the vertical, slide out the tube by an additional hole, eg. If you have the hinge on the second hole up from the bottom, then the tube in the collector needs to be on the third hole, with 2 holes showing (one for the hinge).
- Select the correct hole to give the correct mounting angle and cut off just above the hole on both upright sections. Typically this will be between 15 and 20 degrees.

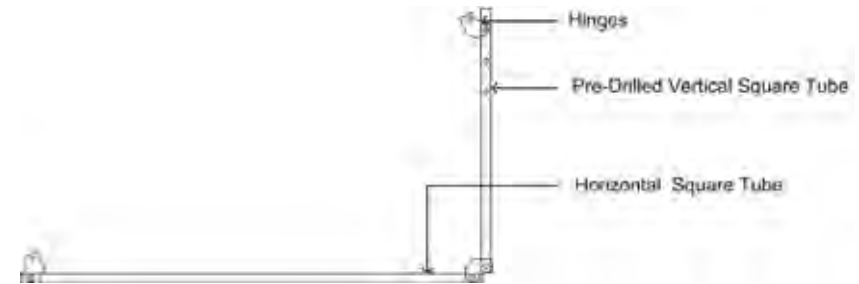

Example: If your roof pitch is 5 degrees and you need 20 degrees, select the second hole (15 degrees) and cut above this as this gives an angle of 20 degrees. Slide the tube in the collector to the second hole (one hole outside to connect to the hinge). If your roof is 5 degrees to the south, then you need 25 degrees, so select and cut above the third hole and slide the tube in the collector out to the fourth hole

15. Installing Solar Heat Collector with a NS Frame on to the roof

- To connect the NS frame to the collector, slide the 4 short pieces of 550mm square tube supplied with the collector into the top hat section underneath the collector in each corner.
- Slide to the second bolt hole and secure using the supplied bolts, washer and nuts. The 4 pieces of tube will now have one bolt hole showing on each corner. **NOTE** If you choose to mount the PV Panel to the collector (See the 3 available frame Arrangements for further details in Step 24) use one of the square tubes from the PV Frame Kit and fit to the Top Hat section.
- Making sure the collector is facing the correct direction (the





- inlet/outlet cover plates with 6 nuts are on the south side) slide the collector and the square tube into the frame hinges on the northern side and fit bolts.
- d) Standing at the rear of the solar heat collector, lift the collector until the rear is high enough to bring up the vertical/uprights of the frame and then connect the hinge to the square tube. Fit bolts and nuts to secure.
 - c) Tighten and check all bolts.
 - d) There are 2 “spacers” provided which can be screwed to the frame to correctly separate and position the frame prior to putting the collector on top.

For a tiled roof

- e) Position the solar collector with the attached NS Frame into the correct position facing North. You may need to use rope to temporarily hold the frame and collector in position.
- f) Using the four frame-mounting brackets or other mounting brackets, fix the frame to the roof. To fit the brackets, slide back tiles in the correct location and screw into the roof truss. Ensure that the structure is secure.
- g) Place the 4 short pieces of 550mm short square tube over the tiled roof brackets
- h) Drilling a 8mm hole into the square tube and bracket and secure the collector to the bracket by using the nuts and bolts supplied with the collector.

For a metal roof

- c) Position the solar collector with the attached NS Frame into the correct position facing North.
- d) Fix the frame to the roof with roofing screws, in at least six locations. Ensure that the structure is secure.

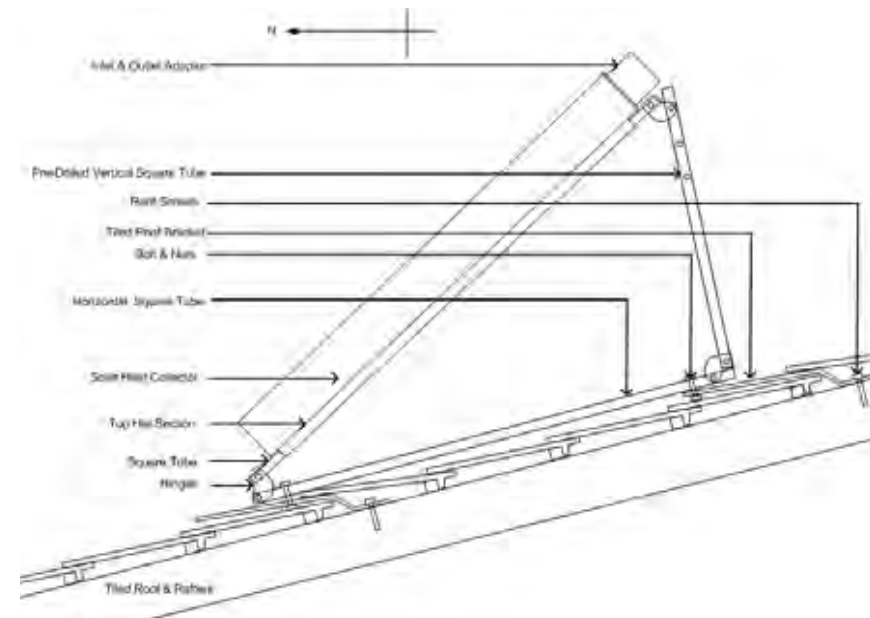
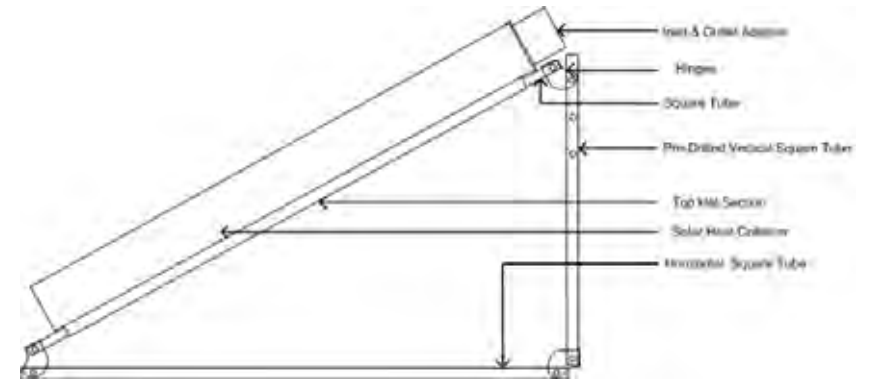

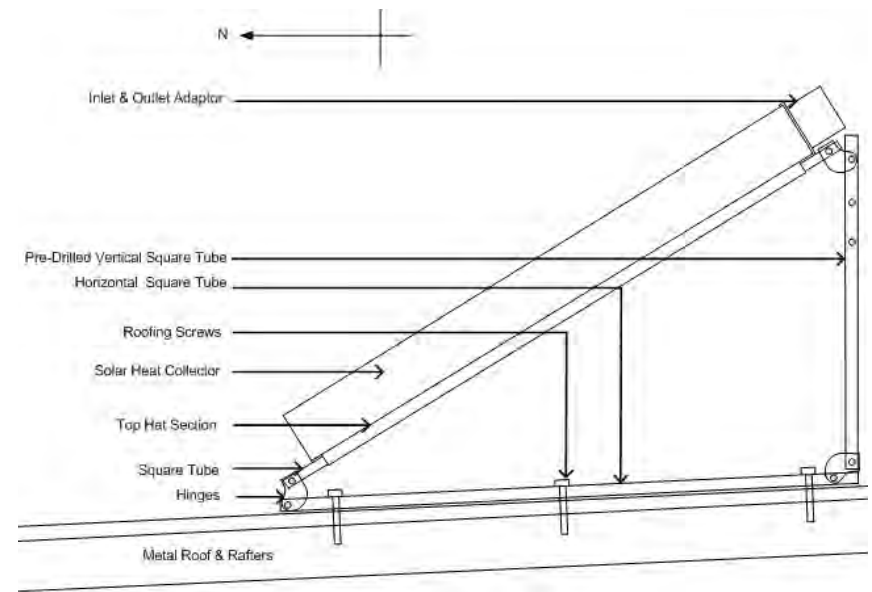

16. Assembling the EW Frame for the Solar Heat Collector

Notes: the longest section of tube sits flat on the roof with the shortest section being the vertical/upright. On the Elevation Frame NS (the smaller frame kit), the longest section sits on top of the Elevation Frame EW.

Depending on the orientation and pitch of your roof, your Sun Lizard may come with an Elevation Frame. In the previous section, "selecting your location", you would have chosen your installation location and also acquired the appropriate accessories to complete the installation.

- The Elevation Frame EW can be used to create a horizontal platform for the Elevation Frame NS. The EW Frame is used for buildings with an east or west facing roof.
- The EW Frame consists of a long piece of square tube which is fitted to the roof and two shorter square tube which make up the horizontal and vertical tube for the EW Frame. The shorter vertical upright tube is cut to length to adjust the appropriate height for a vertical platform. Three hinges are then used to connect the 3 pieces of square tube.
- Assemble two sets of the tube and hinges as shown in the right to create the EW Frame.

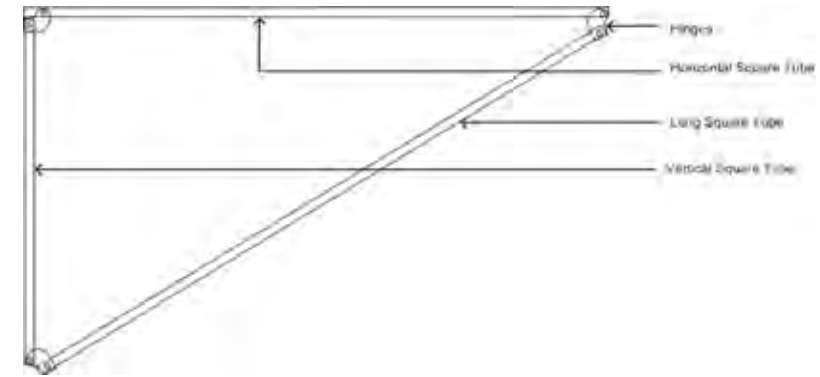

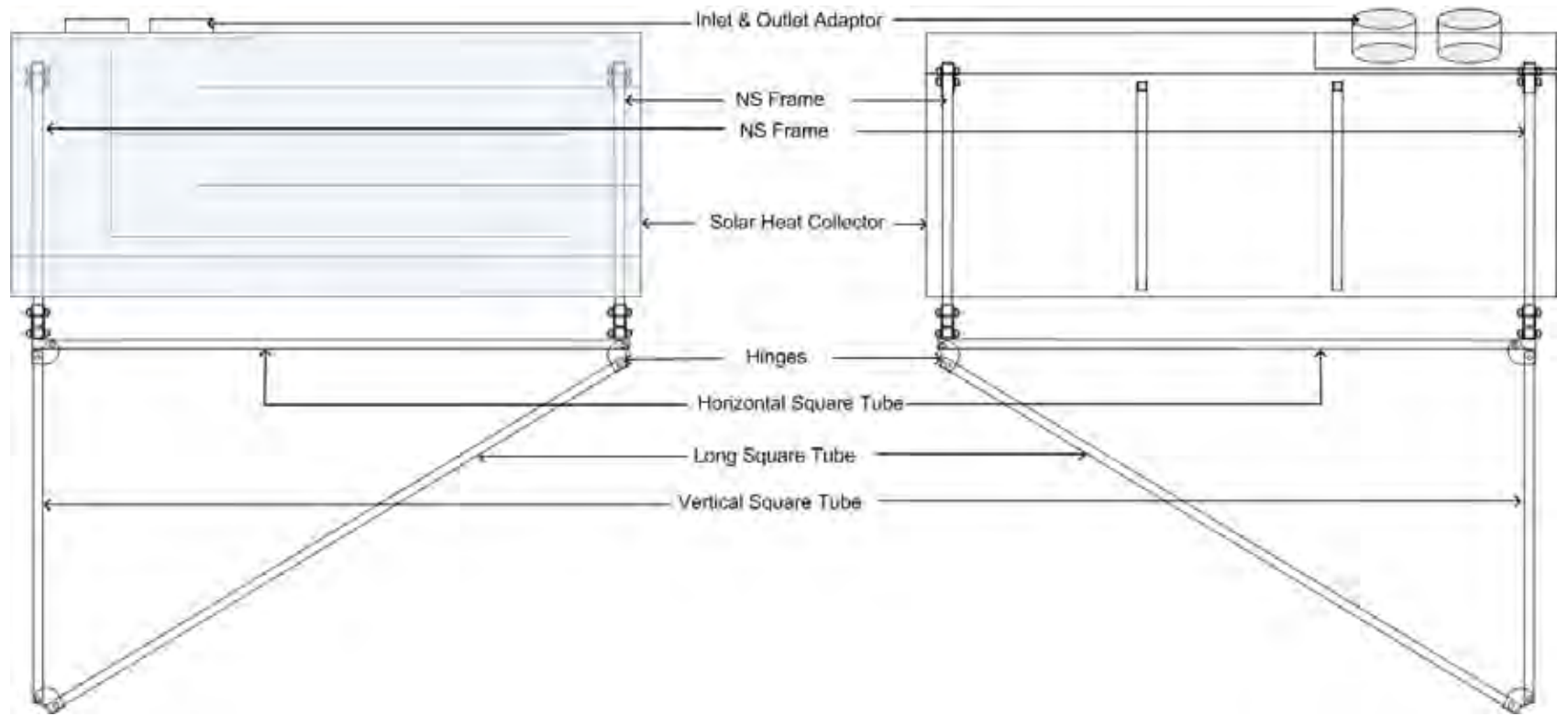

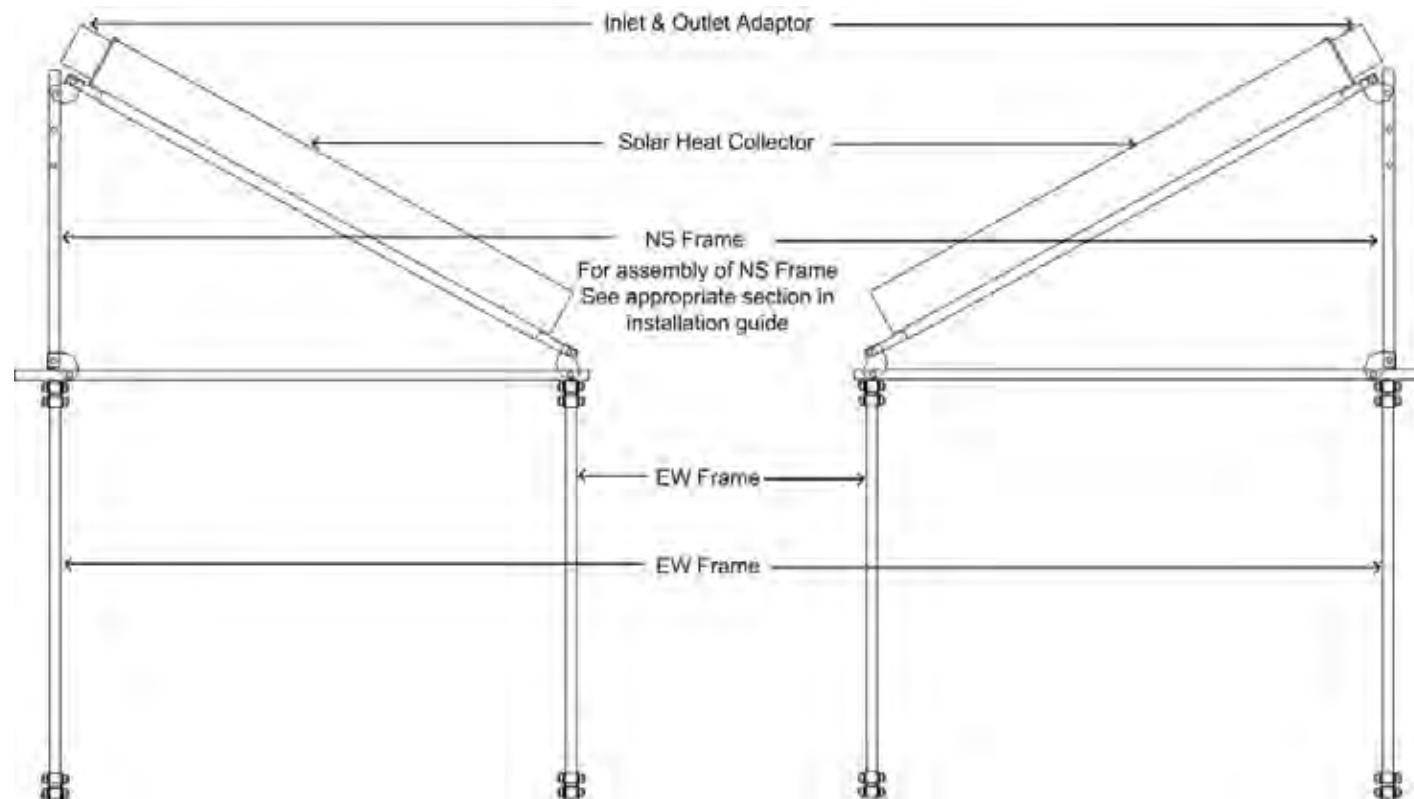

17. Installing the Solar Heat Collectors with an EW Frame

For a tiled roof

- (a) Position the Elevation Frame EW into the correction position.
- (b) Check that the orientation is correct, by adjusting the pitch of the frame to produce a level surface. To get the correct angle before cutting the tube, place the assembled frame on the roof overhanging the side and then using a spirit level, get the top of the frame horizontal, then mark the vertical tube where it needs to be cut. Cut the tube and bolt together using the hinge and bolts supplied.
- (c) Using the four frame-mounting brackets or other appropriate fixing components, fix the frame to the roof. To fit the brackets, slide back tiles in the correct location and screw into the roof truss. Ensure that the structure is secure. The frame comes with two spacers to ensure that the two sides of the frame are correctly positioned in relation to each other. Use the spacers at the base of the frame first and once the frame is secured, screw the spacers to the top of the frame to brace and space the frame prior to locating the Elevation Frame NS on top. You can use the spacers to temporarily hold the frame together while you position it on the roof. Remove tiles and confirm that the brackets can be screwed/bolted to roof joists, mark the bracket position on the frame, and then drill bolt holes. Fix the brackets to the roof joists and then bolt the frame to the brackets.
- (d) Once secure, the frame should be checked again to ensure a level surface at the top of the frame. Check with a spirit level.
- (e) Now mount the Elevation Frame NS onto the level top surface of the Elevation Frame EW. The longest section sits on top of the EW frame. The mounting holes at the end of each frame section should match and both frames should be bolted to each other at each corner.
- (f) Adjust the Elevation Frame NS so that it creates a pitch appropriate to your location (see chart 1) and faces North (see selecting a location). Typically this angle will be between 15 and 20 degrees. The predrilled holes in the Elevation Frame NS vertical/upright section are at 5 degree intervals starting at 10 degrees. Select the correct hole and cut off just above the hole on both upright sections. See section 13 for more information.
- (g) The installation is now ready for the mounting of the Solar heat Collector. See section 13 for details on connecting the solar heat collector to the Elevation Frame NS.

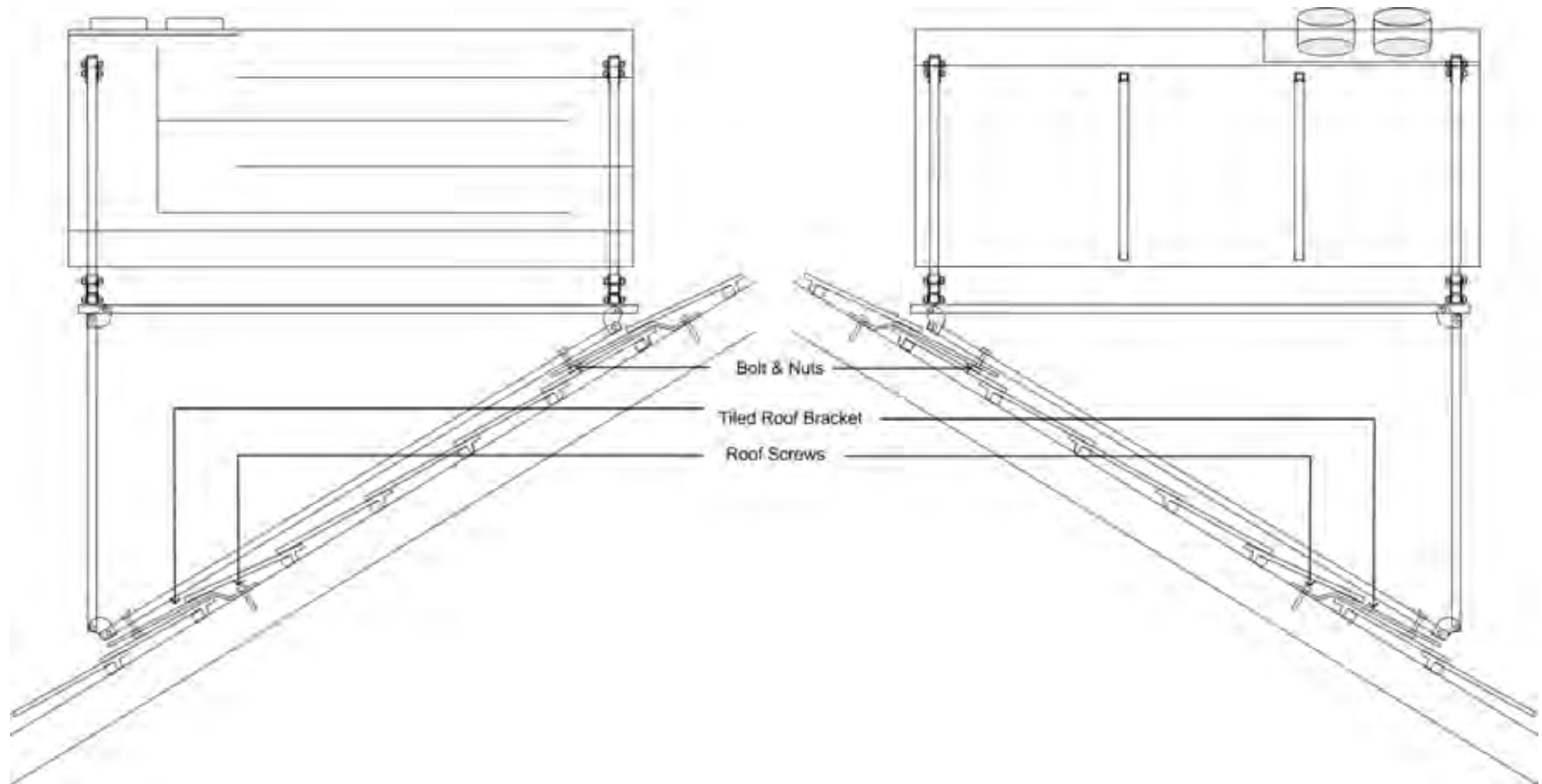

For a metal roof.

- a) Position the Elevation Frame EW into the correction position.
- b) Check that the orientation is correct, by adjusting the pitch of the frame to produce a level surface. To get the correct angle before cutting the tube, place the assembled frame on the roof overhanging the side and then using a spirit level, get the top of the frame horizontal, then mark the vertical tube where it needs to be cut. Cut the tube and bolt together using the hinge and bolts supplied.
- c) Fix the frame to the roof with the appropriate bolts and/or brackets, in at least six locations. Ensure that the structure is secure. The frame comes with two spacers to ensure that the two sides of the frame are correctly positioned. Use the spacers at the base of the frame first and once the frame is secured, screw the spacers to the top of the frame to brace and space the frame prior to locating the Elevation Frame NS on top.
- d) Once secure, the frame should be checked to ensure a level surface at the top of the frame. Check with a spirit level.
- e) Now mount the Elevation Frame NS onto the level top surface of the Elevation Frame EW. The longest section sits on top of the EW frame. The mounting holes at the end of each frame section should match and both frames should be secured to each other at each

corner.

- f) Adjust the Elevation Frame NS so that it creates a pitch appropriate to your location (see chart 1) and faces due North (see selecting a location). Typically this will be between 15 and 20 degrees. The predrilled holes in the Elevation Frame NS vertical/upright section are at 5 degree intervals starting at 10 degrees. Select the correct hole and cut off just above the hole on both upright sections. See section 13 for more information.
- g) The installation is now ready for the mounting of the Solar heat Collector. See section 13 for details on connecting the solar heat collector to the Elevation Frame NS.

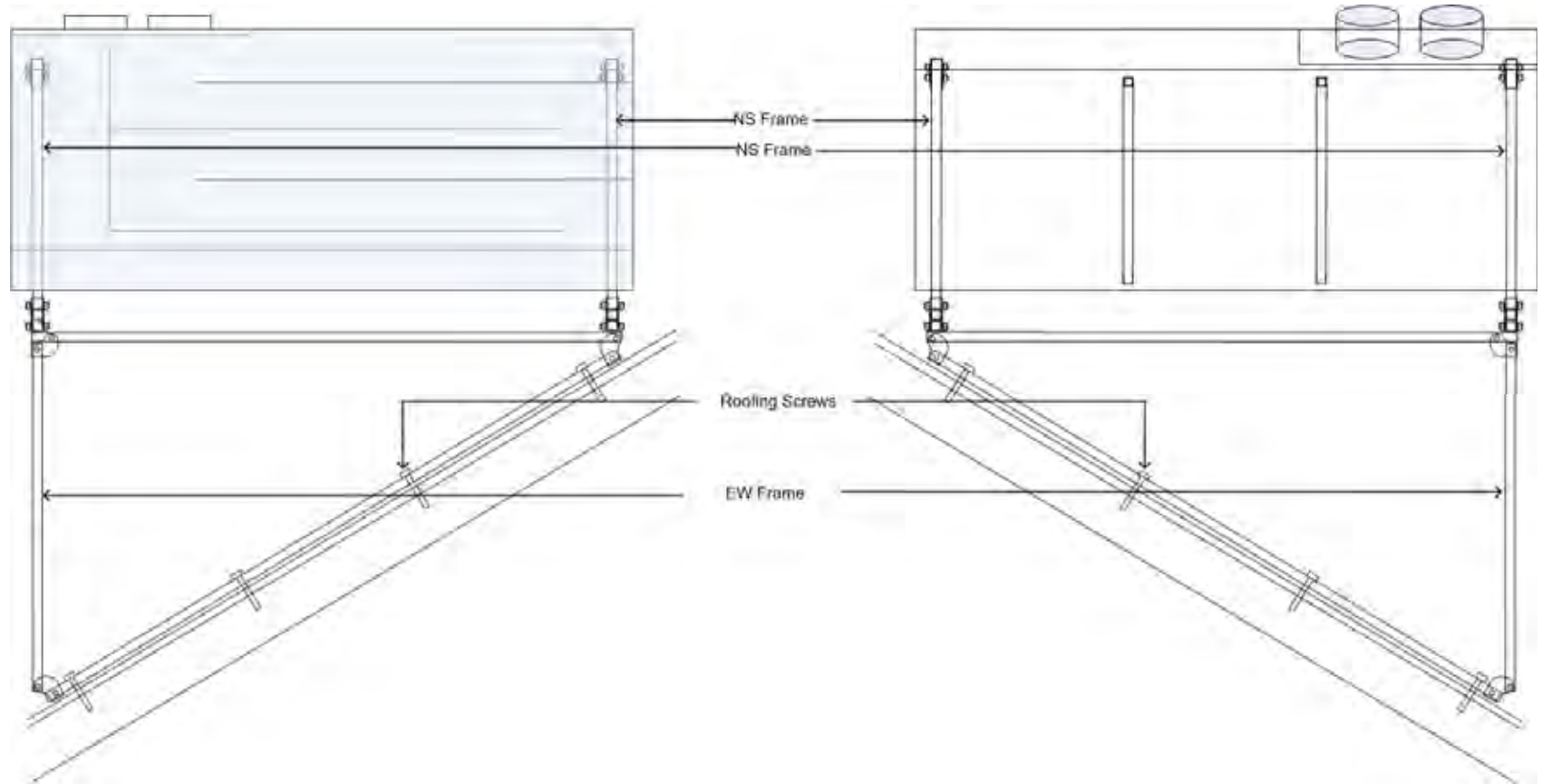

18. Penetrating the Roof

Roof with Ceiling Cavity

- a) Select location for roof penetrations and remove tiles or cut 155-160mm holes in metal.
- b) Cut rubber of Dektite or Aquaseal to suit 150mm pipe and fit pipe into rubber.
- c) Place into hole in roof but do not seal at this stage.
- d) Fit 90 degree bends to pipe and tape temporarily
- e) Cut and fit pipe to 90 degree bends and fit to inlet and outlet pipe of solar heat collector and tape temporarily

Roof with no Ceiling Cavity

- a) Select location for ceiling return vent by checking inside the building where any timber structures are located and marking and cutting plaster first. Mark and cut the holes for the ceiling register using the template on the register box.
- b) Cut hole in metal roof matching hole in plaster.
- c) Cut rubber of Dektite or Aquaseal to suit 150mm pipe and fit pipe into rubber.
- d) Place into hole in roof but do not seal at this stage
- e) Select location for heating outlet pipe by checking inside the building where any timber structures are located and marking and cutting plaster first.
- f) Cut hole in metal roof matching hole in plaster.
- g) Cut rubber of Dektite or Aquaseal to suit 150mm pipe and fit pipe into rubber.
- h) Place into hole in roof but do not seal at this stage
- i) Fit 90 degree bends to pipe and tape temporarily
- j) Cut and fit pipe to 90 degree bends and fit to inlet and outlet pipe of solar heat collector and tape temporarily

Select the location of the exhaust flue:

- a) Remove tiles if it is a tiled roof) or cut a 160mm hole in the metal roof.
- b) Cut rubber off Dektite or Aquaseal to suit 150mm pipe and tightly fit pipe into rubber.
- c) Place into hole in roof. Do not seal or screw the Dektite or pipe to roof at this stage.

Roof with Ceiling Cavity

The Sun Lizard Single Collector requires three openings in the roof to allow 150mm pipe ducting to be connected to the inlet, outlet and exhaust vents inside the building. Typically this is done using Dektites or Aquaseals. Pipe coming from the Solar Heat Collector joins a 90 degree bend and then passes through the Dektites or Aquaseals so it goes into the ceiling cavity.

If the solar heat collectors are mounted on frames then the holes should be immediately behind the collector to minimise pipe length.



Roof with no Ceiling Cavity

If there is no ceiling cavity, the ceiling return vent and the heating outlet vent will connect directly to the roof.

It is critical that the length of ducting is kept short as all ducting on the roof needs to be weatherproof and insulated to minimise heat loss.

If the solar heat collectors are mounted on frames then the holes should be immediately behind the collector to minimise pipe length.



19. Fitting ceiling diffuser

After selecting the location for ceiling diffuser(s)

- Check inside the ceiling cavity for where timber structures are located.
- Mark and cut plaster for an exact location.
- Mark and cut the hole(s) for the ceiling diffuser using the template on the diffuser box. This diffuser will draw warm air from the ceiling into the Fan Box.
- Fit ceiling diffuser into plaster ceiling and lock.

For buildings with no ceiling cavity, tape or screw the ceiling register to the 150mm pipe going through the roof before fitting and locking into place

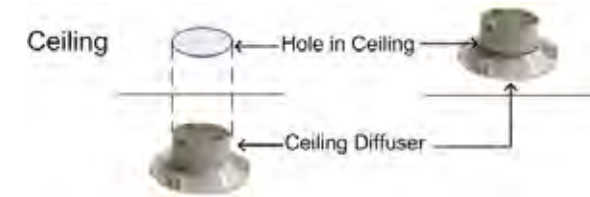

20. Connecting ducting

NOTE: Heating Duct is not supplied with the system. For more details on various types of Heating Ducts, please see **the Appendix** at the end of this document.

Roof with Ceiling Cavity

- Connect one end of the insulated flexible ducting to ceiling diffuser using duct tape and make sure it is well taped and sealed.
- Stretch the insulated flexible duct to the fan box and cut duct to length (**NOTE:** the shorter the duct the less resistance in airflow, the more effective the system will perform)
- Continue connecting the insulated flexible duct from fan box to the pipe going through the roof to the solar heat collector.
- Connect the pipe from the solar heat collector (hot air coming from collector) to the airflow control box with the single opening (see diagram opposite).
- Connect ducting from the airflow control box to the exhaust flue gal pipe and the heating duct or ceiling register for heating, making sure that ducting is kept to a minimum.

Roof with No Ceiling Cavity

- Connect one end of the insulated flexible ducting to ceiling diffuser using duct tape and make sure it is well taped and sealed.
- Stretch the insulated flexible duct to the fan box and cut duct to length (**NOTE:** the shorter the duct the less resistance in airflow,

HANDY TIPS

- Direction of air flow on the Fan and Airflow Control Box indicated in diagrams below.



- Ducting should be secure and airtight.
- You can use metal gal pipe instead of the supplied insulated flexible ducting as it has even less resistance in air flow.

You should plan out the installation of the ducting to maximise efficiency and produce the most effective airflow system for the

- the more effective the system will perform)
- (c) Continue connecting the insulated flexible duct from fan box to the pipe going through the roof to the solar heat collector.
 - (d) Connect the pipe from the solar heat collector (hot air coming from collector) to the airflow control box with the single opening (see diagram opposite).
 - (e) Connect ducting from the airflow control box to the exhaust flue gal pipe and the heating duct or ceiling register for heating, making sure that ducting is kept to a minimum.

building. **Diagram 1** in this installation guide provides a simple explanation of airflow and the duct installation for any building.

One thing to consider is that many buildings are quite warm on the northern side and cold on the southern side. If your building is like this, consider placing the ceiling vent close to the north side to take this warmer air out to the Sun Lizard for heating and pump it back to the southern side of the building. This effectively makes it a smart, active heat shifter. In summer, the northern side of the building is also the side most likely to be the hottest, so this inlet installation is the most effective for summer as well as winter.



21. Connecting the Electronic Control System (ECS), to Cable and Switch

Please note Make sure the cable and switch are installed before connecting the PV panel on the roof.

For walls with a 90mm wall cavity:

- Locate the wall mounted switch in an appropriate, accessible location.
- Locate the top plate directly above the desired position of the wall mounted switch
- Drill a 15mm diameter hole into the top plate
- Connect one end of the 15m cable to the socket labelled 'Control Panel' on the ECS
- Feed the 15m cable down the 15mm diameter hole
- Create a small hole in the plasterboard to where you want to fit the switch
- Draw the suspended cable inside the cavity through the hole in the plasterboard
- Clip the other end of the 15m cable to the back of the switch
- Remove top cover of the switch
- Place the switch against the wall
- Using plasterboard screws (not supplied), screw the switch into position. (If gang plate is behind plasterboard (usually for new homes) use the screws supplied in the switch)
- Reposition the top cover of the switch.

For solid walls:

- Use a convenient cupboard or wardrobe to run the cable in to your desired location

or

Use conduit and screw/stick conduit to the desired location on the wall and run cable to the desired location.

- Then follow steps (h) – (l) in the above instructions for a 90mm wall cavity.

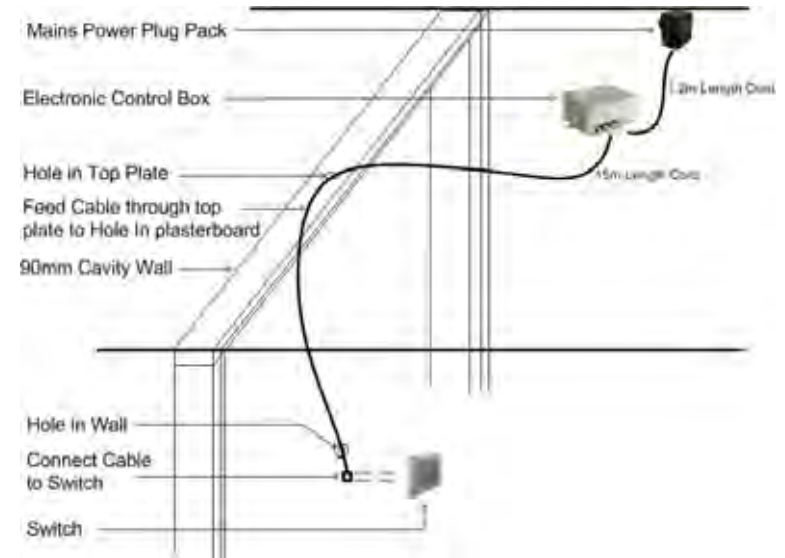

For walls with 90mm wall cavity

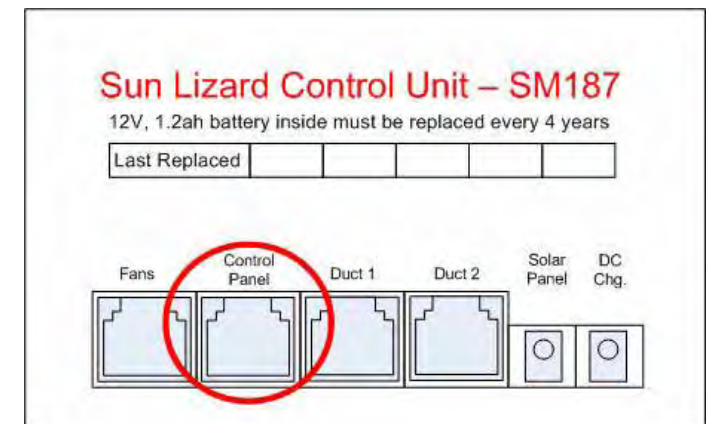

22. Connecting the Electronic Control System (ECS), to Fan Box

- a) Using the cable attached to the Fan Box, connect the cable to the socket labelled 'Fans' on the ECS.

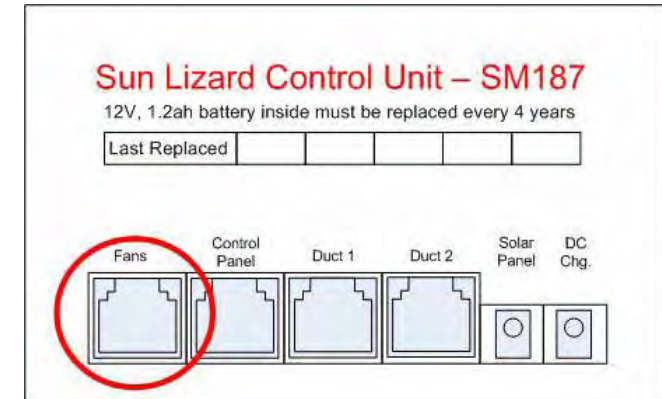

23. Connecting the Electronic Control System (ECS) to Air Flow Control Box

- a) Using the cable attached to the Air Flow Control Box, connect the cable to the socket labelled 'Duct 1' on the ECS.

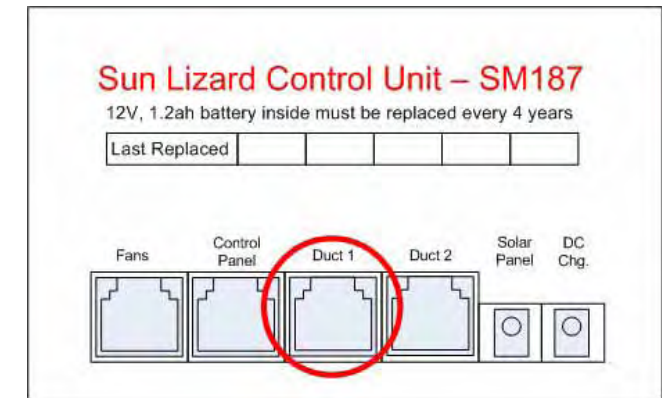

24. Connecting the Electronic Control System (ECS), to PV Panel

- Place the **PV Panel face down** on the roof inside the packing box it came in.
- Unscrew the cover off the junction box on the PV panel
- Use a razor blade or Stanley knife to carefully puncture a small hole in the rubber grommet at the end of the terminal box.
- Feed the end of the cable with two terminators through the slot into the junction box.
- Unscrew the positive and negative screws and hook the terminators into the appropriate terminal. One terminal labelled 'neg' for Negative, other unlabelled is positive. Replace the cover and screw shut.
- Feed the power cable (labelled PV Power) for the PV Panel through the Dektite.
- Screw back on the cover for the junction box.
- Continue to leave **PV Panel face down** to avoid electricity generation.

NOTE PV panel should be the last device connected to complete the Sun Lizard assembly on the roof!

IMPORTANT



We strongly advise placing a cover (the box it came in or a towel) over the face of the panel until after it has been connected to the power cable to stop it from generating electricity and causing any shorts or electrical faults.

- i) Run the cable down the Dektite to the ECS
- j) Connect the end of the cable to the socket labelled 'Solar Panel' on the ECS.
- k) Turn the PV panel over and when it is turned over the fans should immediately start operating if there is any sunshine.

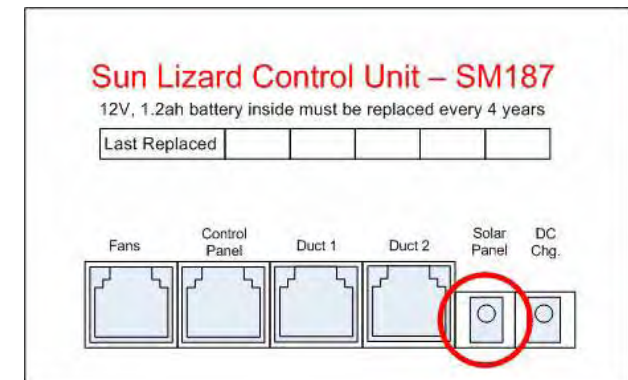

25. Fitting PV Panel on Roof

- Attach PV Panel to adjustable mounting frame. There are three types:
 Use Arrangement 1: if roof is of correct solar angle for your location (see Step 5, Selecting a location for the PV panel)
 Use Arrangement 2: if roof is flat or is east or west facing and want a low profile.
 Use Arrangement 3: if roof is flat or is east or west facing and want allow leaves or debris to easily escape.
- Assemble frames as shown in diagrams below.
- Securely attach PV Panel to mounting frame using nuts and bolts supplied. Use bolt washer and one nut to lock the bolt to the PV frame before fixing to the mounting frame. See detail below:



- Fix the supplied mounting frame with PV panel to the roof using roofing screws for metal roof or hoop iron.

Frame Arrangement 1: For Roofs not needing Frame

Bolt flat on roof for roofs with correct solar angle



Frame Arrangement 2: For Roofs needing a frame

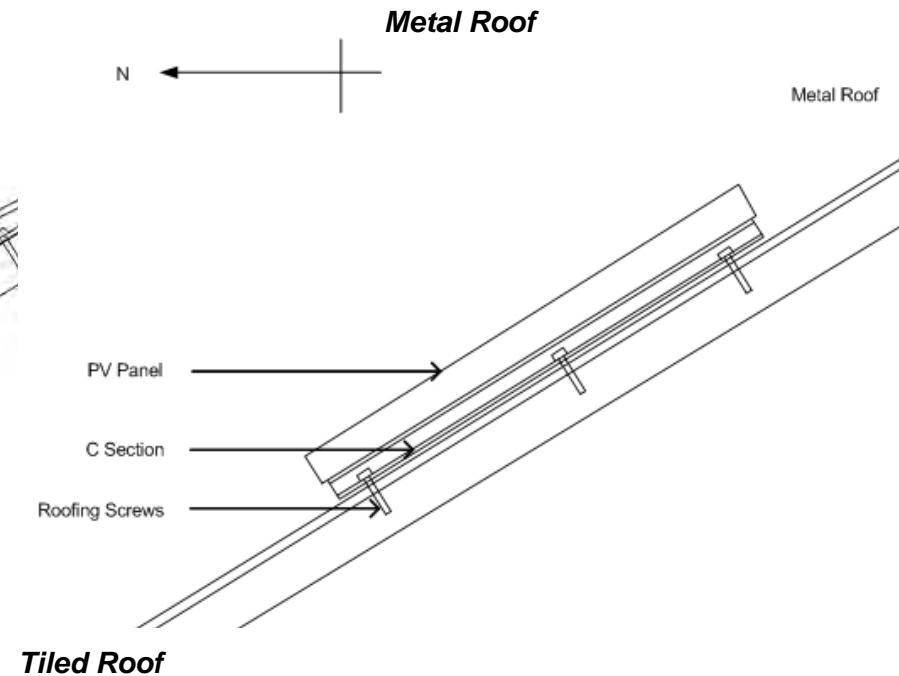
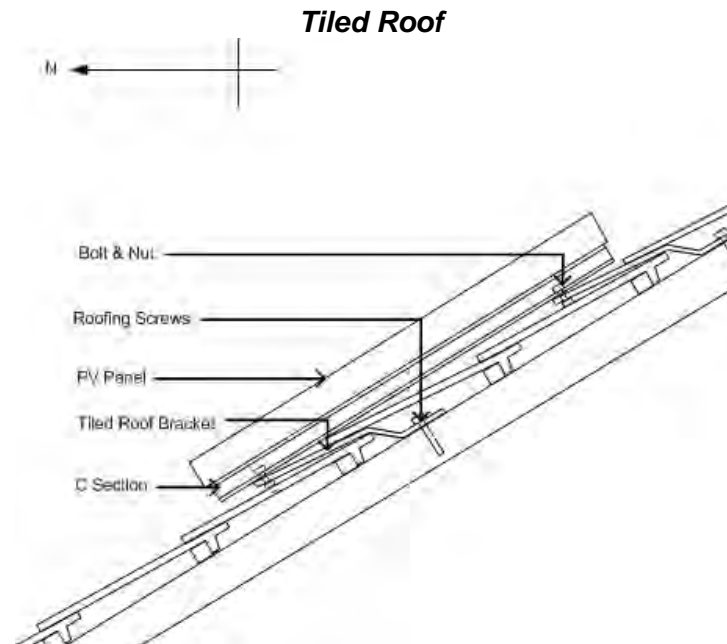

Lower Profile

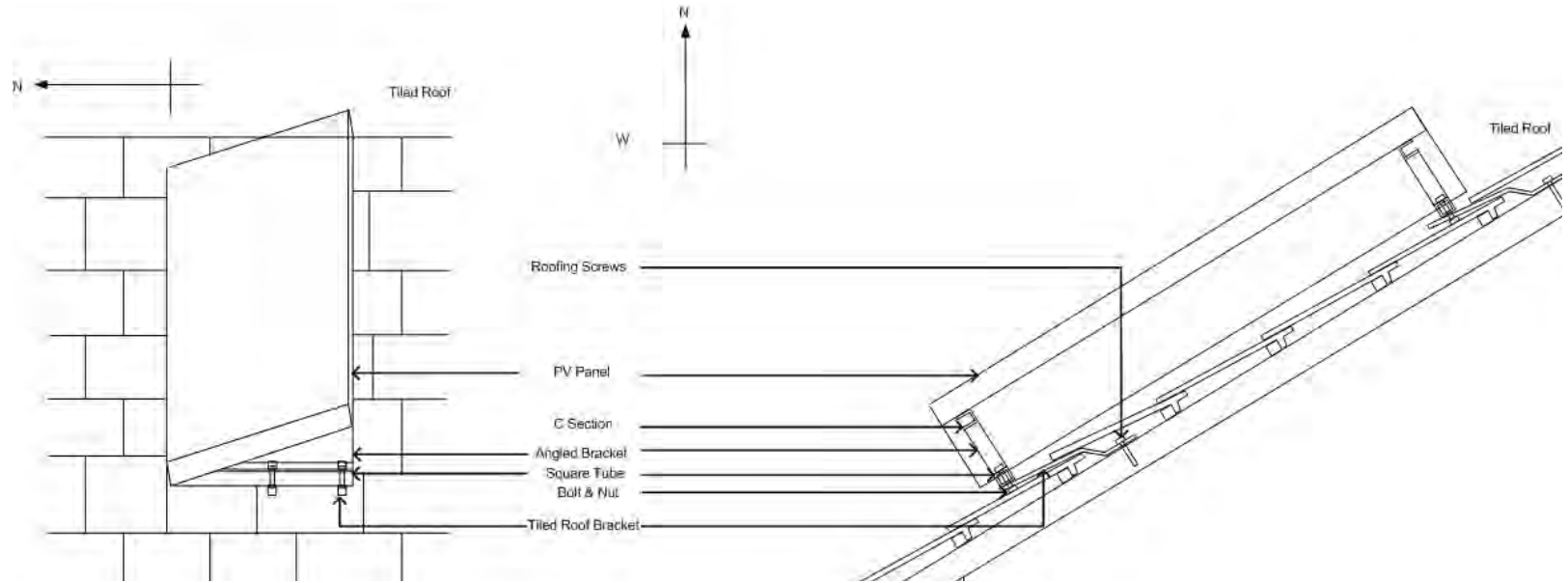

Metal Roof

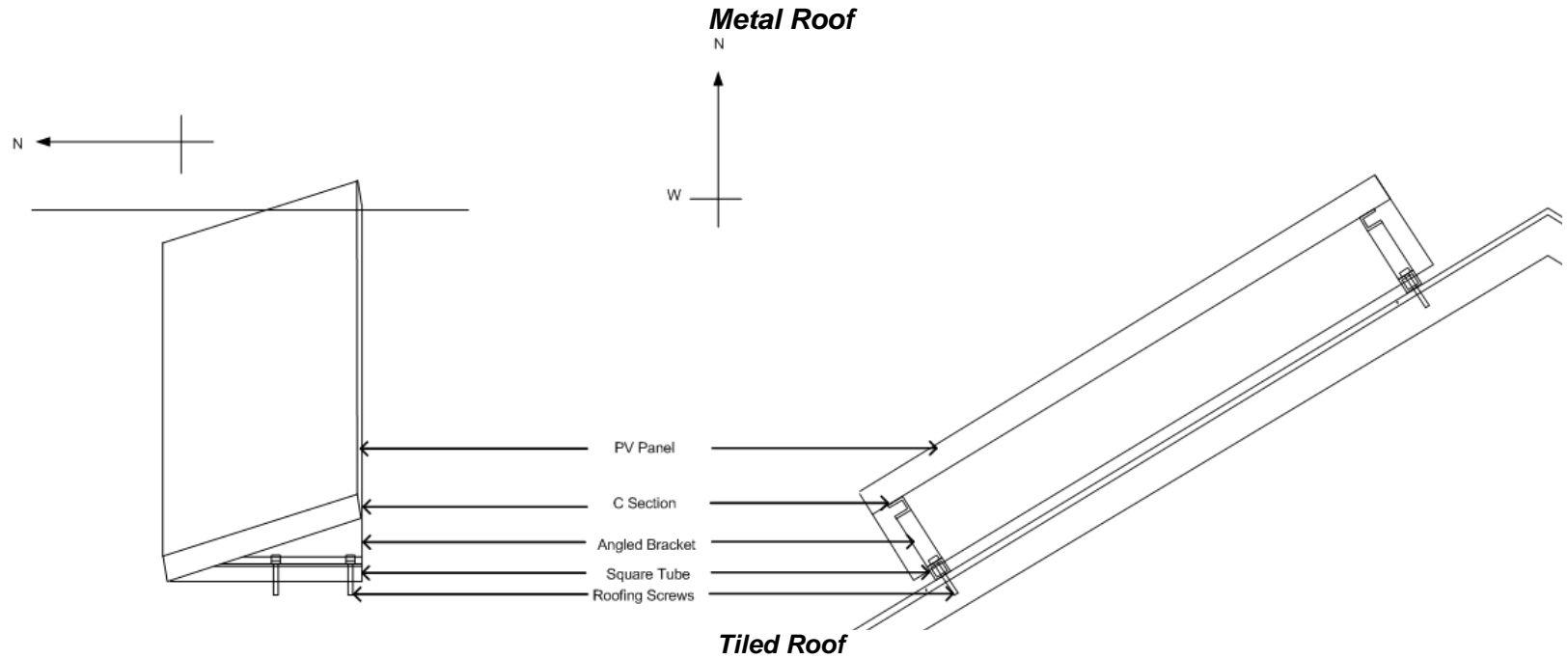

Frame Arrangement 3: For Roofs

needing a frame

Allow air gap for leaves and other debris to fall through
Higher Profile

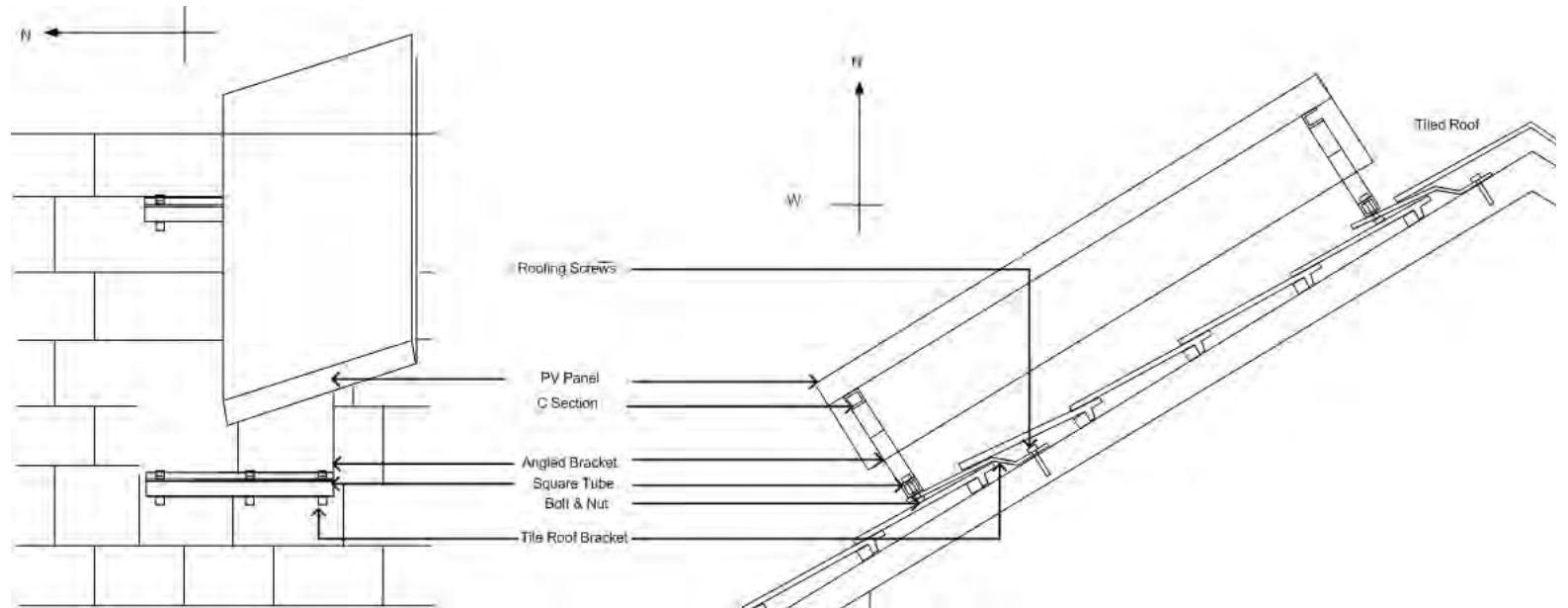

Metal Roof

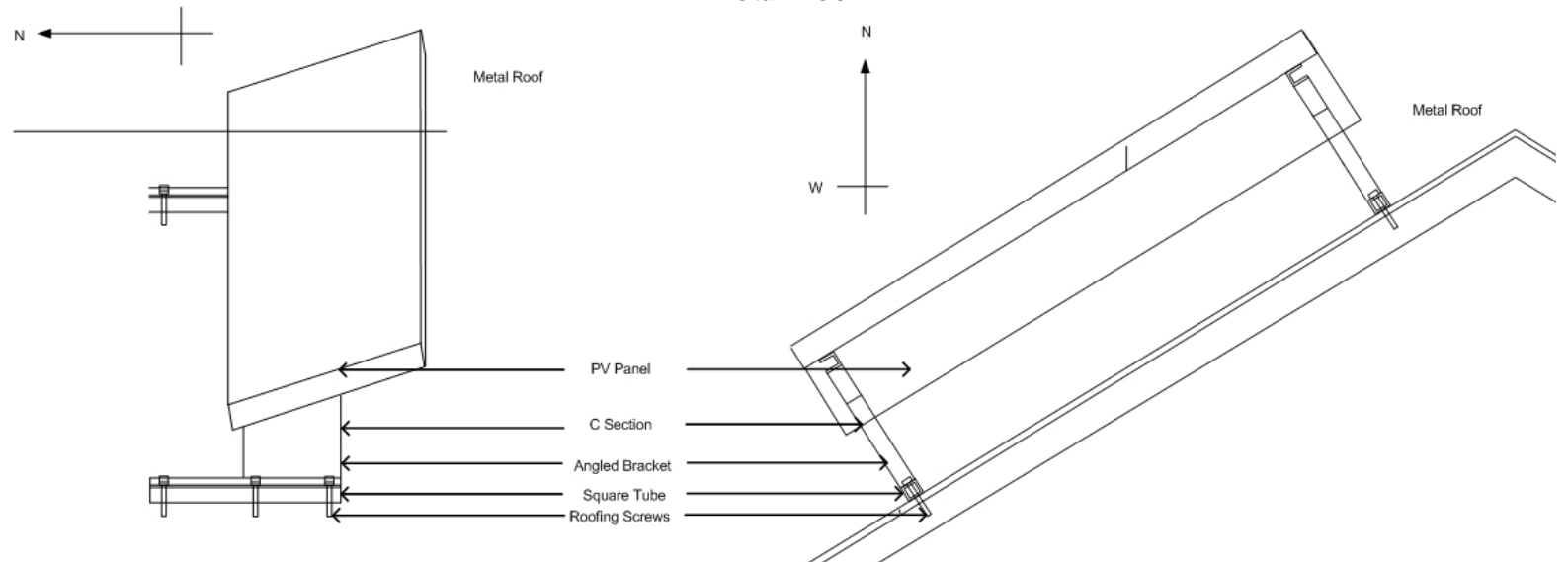

26. Connecting Exhaust Cowl

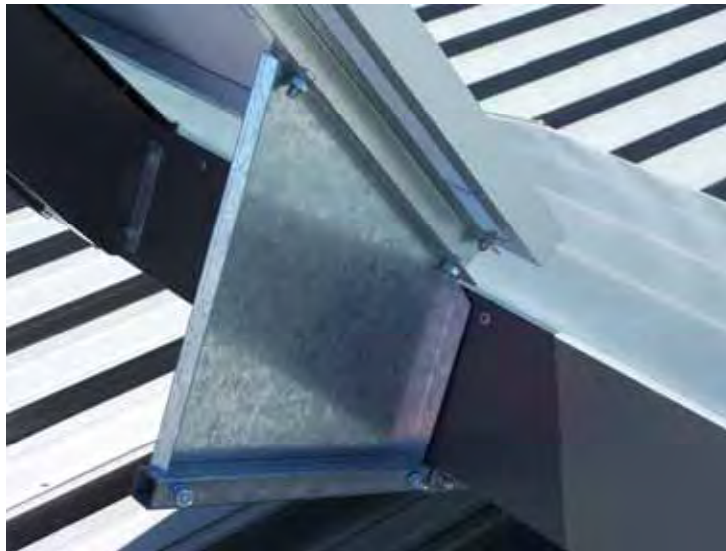

- a) Fit the cowl on the exhaust pipe
- b) Use two tek screws to fix exhaust cowl to pipe

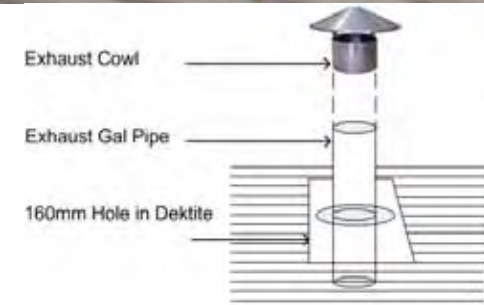

27. Connecting the Electronic Control System (ECS), to Mains Power

(OPTIONAL)

If you wish to have the system available to allow for night time functionality and you have access to a power point inside the roof cavity:

- a) Connect the 240/12 volt plug pack to the socket labelled 'DC Chg.' on the ECS.
- b) Connect the 240/12 Volt plug pack to the 240 volt power source.

If there is no accessible power point, you will need to contact your local electrician to install a power point.

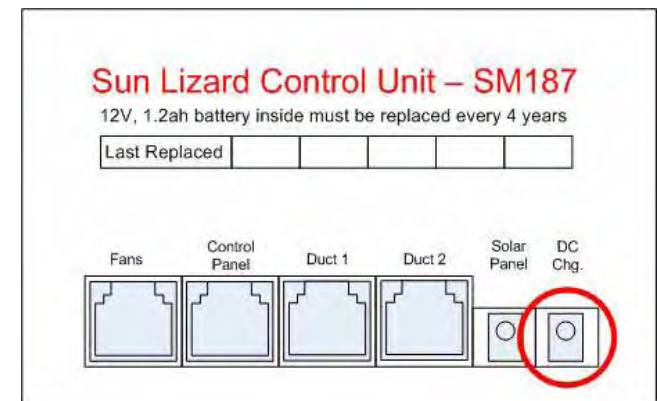

28. Testing the System

- (a) Check that all the functions are working by changing modes on the high/low button on the Control Switch. The system has high or low speed and can be switched off. The heat/cool button must be left at cool mode. The heating function is only used if you upgrade to the our Climate Control System and the system will
- (b) Make sure it is left in the correct mode for the weather conditions.
- (c) Once all the components are connected and tested, the Dektites, Exhaust Cowl, and any other roof penetrations needs to be sealed and checked.

29. Finishing the Job

It is extremely important to ensure that water cannot enter any of the electronic components. They should be mounted so that in the event of severe storms that no backing up of water due to leaves or debris on the roof will allow water to enter any of the boxes. Leave the electronic components accessible in the event of failure.

30. Switch Operation

The wall switch operates in the following ways;

The fan switch changes from OFF to LOW to HIGH by pressing the button. A short beep indicates low, two short beeps is high.

The Heat/Cool switch changes the Sun Lizard from heating mode to cooling mode. The LED light is on when in Heat mode.

If the LED's blink it indicates that the unit is on, but at the moment there is insufficient sunlight to operate the Sun Lizard in the selected mode. It is not necessary to change the switch mode or turn off the Sun Lizard unless you want too as it does not use any energy. It will reactivate in the last mode set when the sun is available the next day.

If the switch is in cooling mode and the optional 12 volt plug pack is connected to mains power, the Sun Lizard will operate 24 hours a day.

It is possible to override the operation and have the fans run 24 hours a day in heating or cooling mode – please contact Sun Lizard for more information.

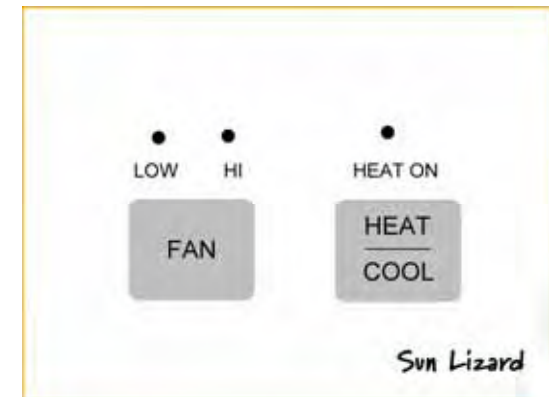

Appendix

Examples Various Types of Heating Ducts

To allow heat to enter back into the building it is preferred that Heating Ducts are used to allow the heat to enter the room at floor level as opposed to a ceiling diffuser which allows the heat to enter at the ceiling. This allows for better heating performance. The following are various types of heating ducts which can be made by your local builder, carpenter or sheet metal company.

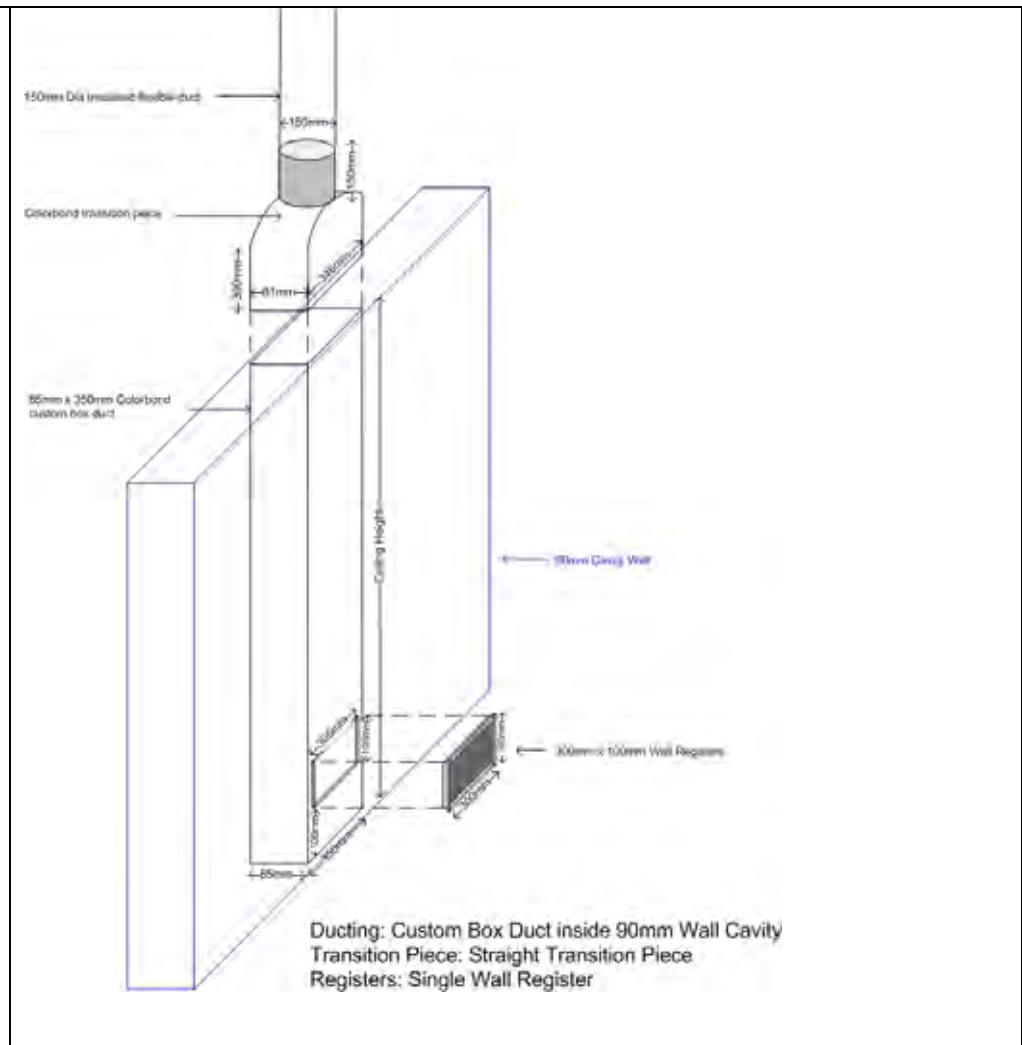
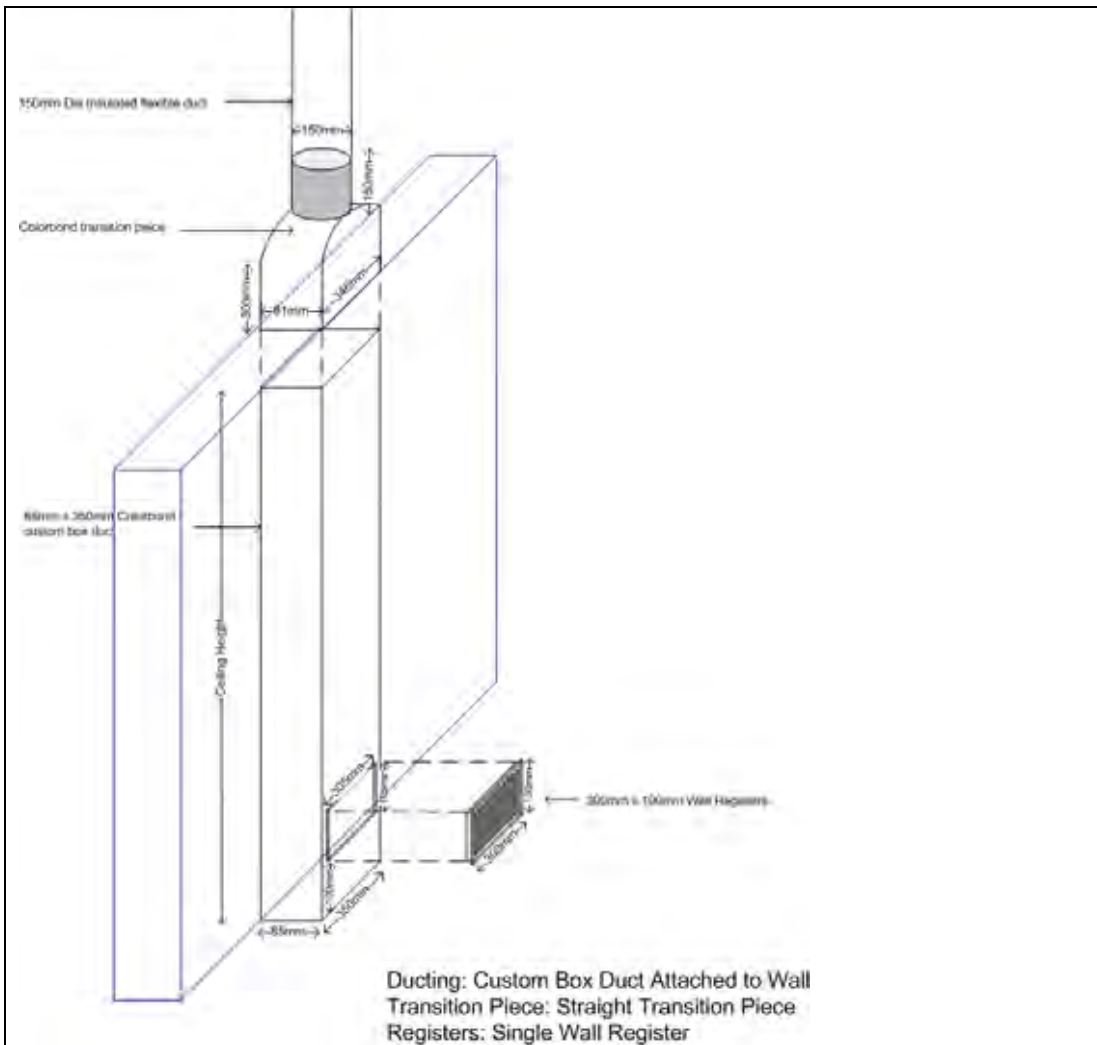

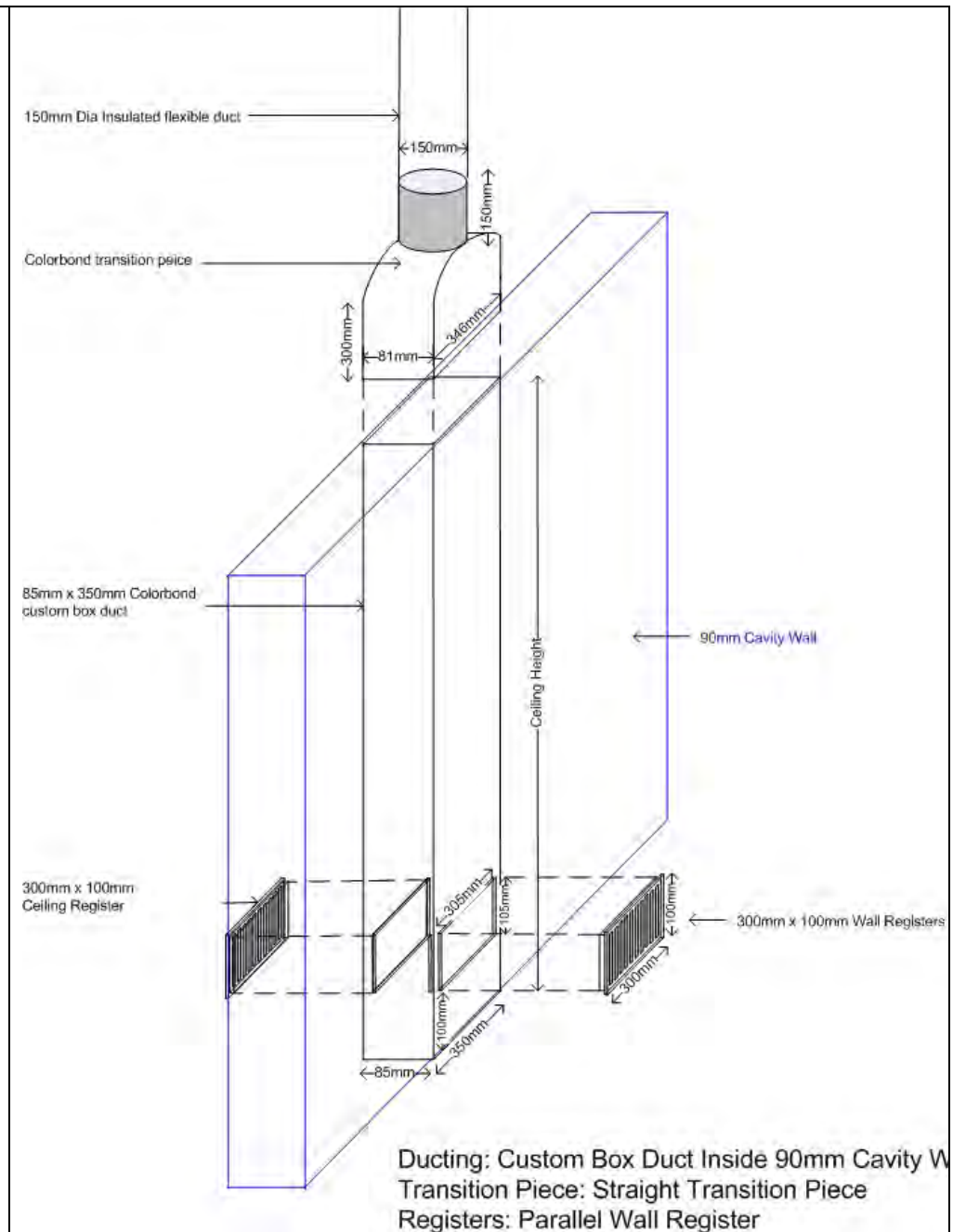
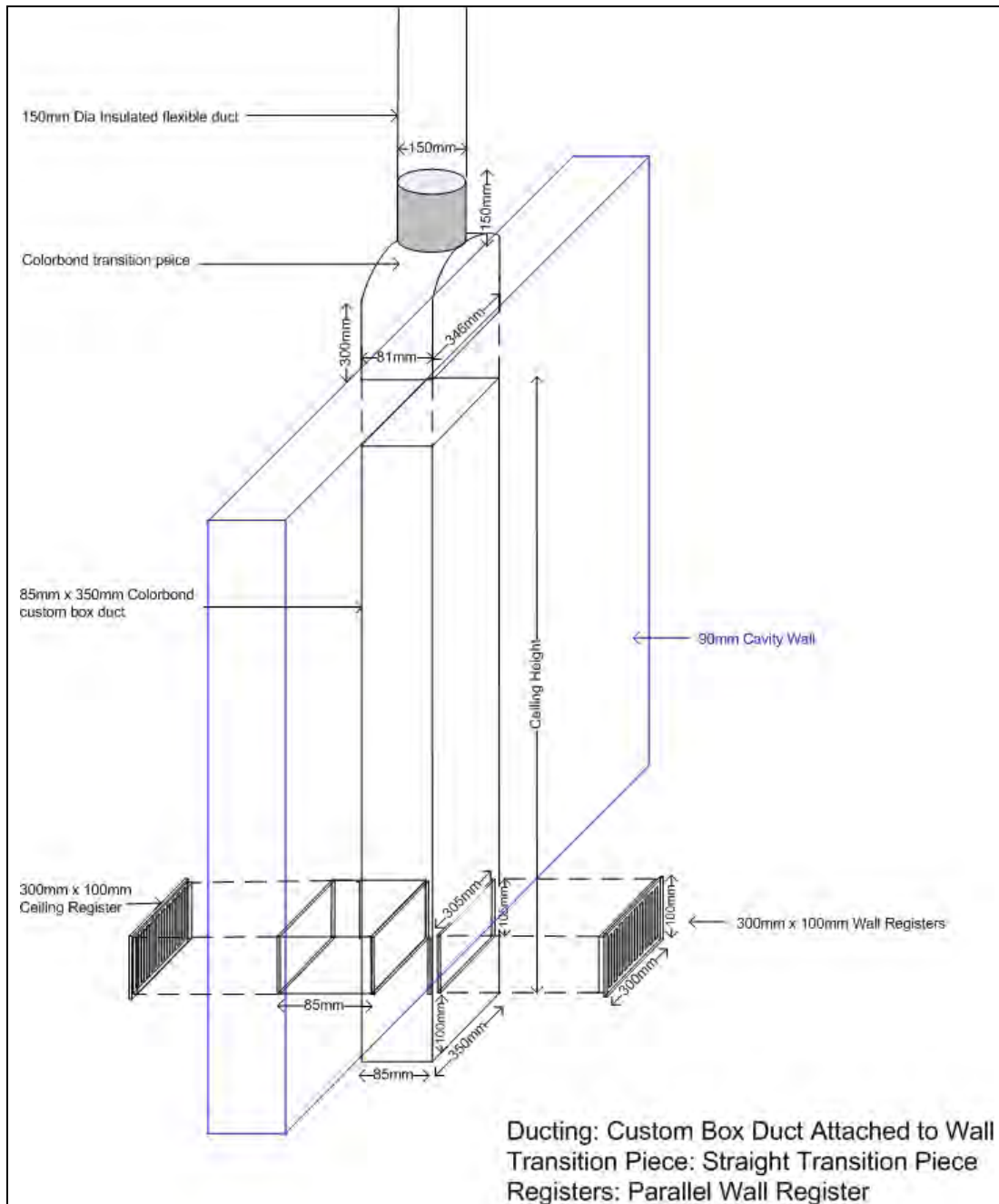

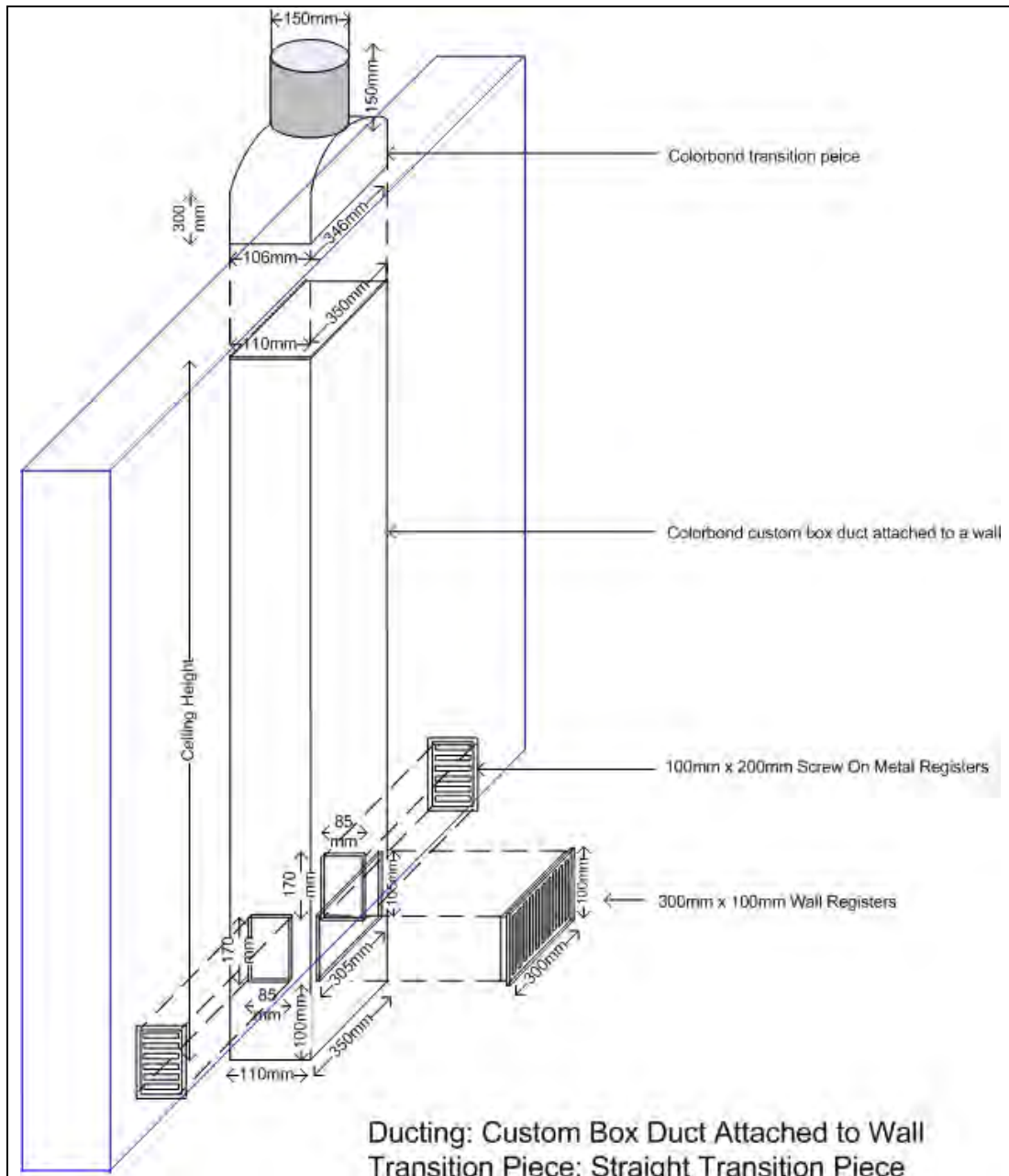

Ducting: Custom Box Duct Attached to Wall
 Transition Piece: Straight Transition Piece
 Registers: 3 Way Wall Registers

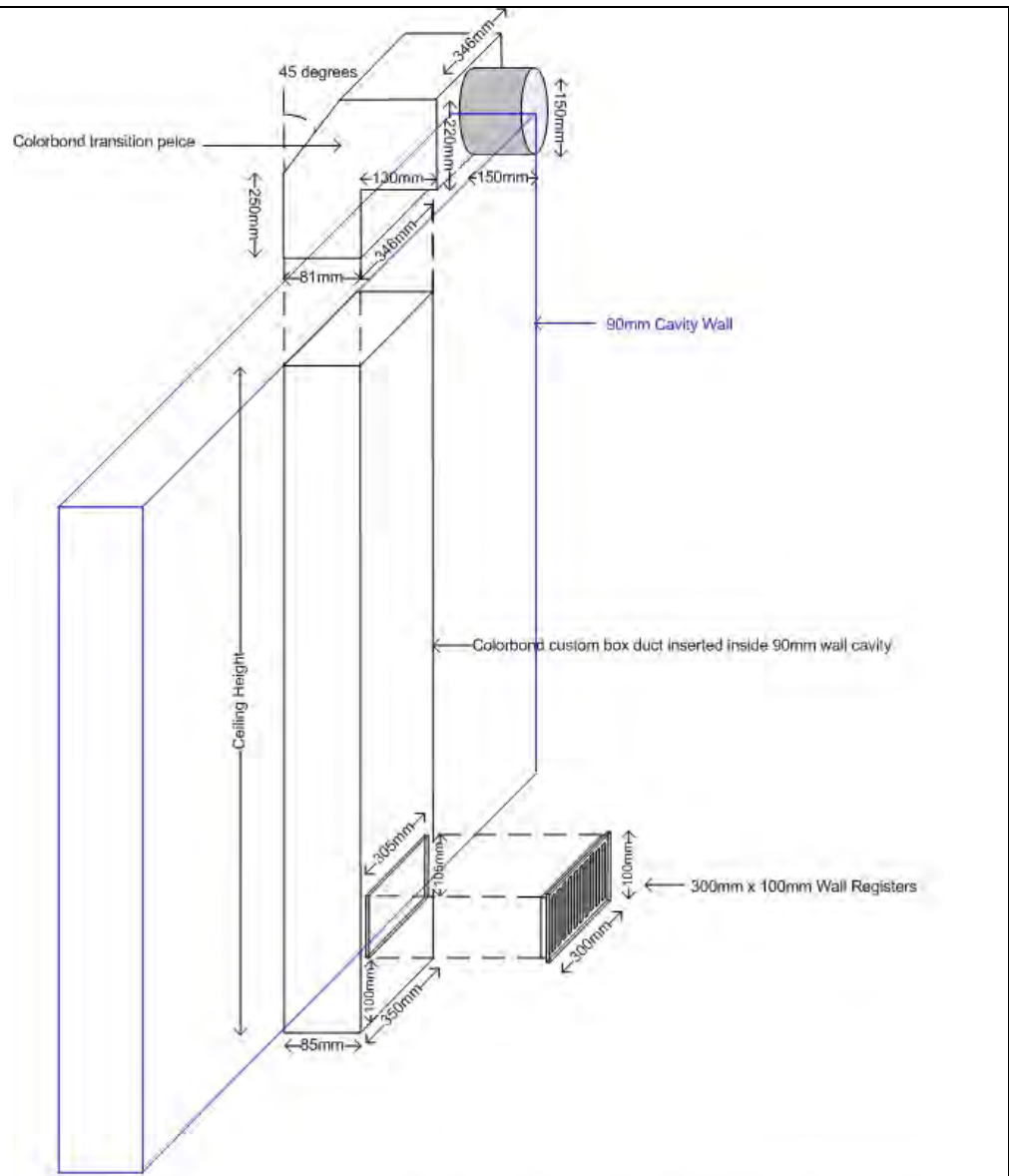

Ducting: Custom Box Duct Attached to Wall
 Transition Piece: Right Angled Transition Piece
 Registers: Single Registers

